

pantograph system, model reduction, PSO, G.A-PID, IMC, LQR

Nasir A. AL-AWAD [0000-0003-3059-4375]*, *Izz. K. ABBOUD* [0000-0002-8344-8585]*,
Muaayed F. AL-RAWI [0000-0003-1841-1222]*

GENETIC ALGORITHM-PID CONTROLLER FOR MODEL ORDER REDUCTION PANTOGRAPH-CATENARY SYSTEM

Abstract

Controlling the contact force between the pantograph and the catenary has come to be a requirement for improving the performances and affectivity of high-speed train systems. Indeed, these performances can also significantly be decreased due to the fact of the catenary equal stiffness variation. In addition, the contact force can also additionally differ and ought to end up null, which may additionally purpose the loss of contact. Then, in this paper, we current an active manipulate of the minimize order model of pantograph-catenary system. The proposed manipulate approach implements an optimization technique, like particle swarm (PSO), the usage of a frequent approximation of the catenary equal stiffness. All the synthesis steps of the manipulate law are given and a formal evaluation of the closed loop stability indicates an asymptotic monitoring of a nominal steady contact force. Then, the usage of Genetic Algorithm with Proportional-Integral-derivative (G.A-PID) as proposed controller appeared optimum response where, the contacts force consequences to be virtually equal to its steady reference. Finally it seems the advantageous of suggestion approach in contrast with classical manipulate strategies like, Internal mode control(IMC) method, linear quadratic regulator (LQR). The outcomes via the use of MATLAB simulation, suggests (G.A-PID) offers better transient specifications in contrast with classical manipulate.

1. INFORMATION FOR AUTHORS

Actually, the complicated conduct of the pantograph-catenary machine received the interest of many researchers many a long time ago. Almost all ancient research have pointed out that, at high speed, better performances can be completed solely if a new layout of the standard system have been carried out, which implied a giant quantity of resources and the exchange of nearly all the structures of the railway systems. As a result, the use of lively pantographs used to be recommended as an alternative of giant investments. Thus, in order to enhance the manage device performances, approximate models of the pantograph-catenary machine have been regarded. Accordingly, many researchers assumed that the complicated dynamics of the catenary may be well approximated with the aid of a linear

* Mustansiriyah University, Faculty of Engineering, Computer Engineering Department, Baghdad, Iraq, muaayed@uomustansiriyah.edu.iq

mechanical system with space-varying lumped parameters. This means that the catenary parameters may additionally be viewed time varying with a change decided by the time pace. Then, as uncertainties are existing in nearly all designed models, many researchers proposed the use of robust manage strategies (Chater et al., 2015), whilst sometimes, the problem was solved by solely tuning popular PID controllers. More recently, a second order sliding mode primarily based control scheme that avoids the measurement of the contact force used to be suggested. Other associated 2nd order sliding mode strategies to this trouble are (Bartolini et al., 2003). However, the usage of the Algebraic Observability Theory, this thinking turns out to require greater knowledge, as it requires the cost of the manipulate force utilized to the higher frame, the speed and the acceleration of the top and lower frames, which can also render the manipulate system complicated and expensive. Hence, in all following works, to operate output feedback, the contact force is evaluated by using skill of load cells whose measurements are compensated by means of accelerometers (Pisano & Usai, 2008). While some other is to take benefit of the improvement in manage theory—this is the idea of energetic manipulate of pantograph-catenary's machine in order to keep an superior contact force. Indeed this has attracted a lot interest in the study of pantograph-catenary interaction. For example, easy nation comments control approach is viewed in (Arnold & Simenon, 2000); in (Giovanelli & Farella, 2016), an LQR is designed the use of a linear pantograph-catenary model, whilst in (Liu et al., 2016) a high order sliding mode variable structure controller is built for the energetic manipulate of pantograph; an evolutionary multiobjective optimization method is utilized taking into account the perturbations brought on by means of the time-varying stiffness of catenary, differential-geometric idea is used for output-perturbation decoupling for a nonlinear pantograph-catenary model in (O'Connor et al., 1997); very recently fuzzy common sense has additionally discovered application in the active control strategies such as in (Pourzeynali, Lavasani & Modarayi, 2007). The pantograph and catenary form an oscillating gadget that is coupled by way of the contact force between the pantograph head and the contact wire. Too giant contact force variation can lead to loss of contact, arcing and wear as properly as harm to the system. The mission of regulating the contact pressure to a pre-specified steady value in the presence of model uncertain-ties and exterior disturbances is suggested.

This paper is arrangement as following: In section 2, the mathematical model of the pantograph-catenary device is represented. Section three it gives the model order reduction. In section 4, we present the controller design of classical and proposed method. Section 5 presents the discussion and evaluation of simulation results.

2. MATEHMATICAL MODEL OF THE SYSTEM

This section is dealing with the components of the electrical train and can be divided by sub-mechanical systems.

2.1. Pantograph

The purpose of pantograph device is to accumulate electrical current from the catenary cable system. In order to gather the current and no longer to interfere with the passing non-electric train below the overhead lines, the essential frame is fold-able and can vertically increase the pantograph head a full-size distance. To gain appropriate current collection,

the pantograph head is sprung and is pushed towards the overhead line. The drive, typically operated via compressed air from the brake system, is used to energy the device to raise or fall, and offers enough uplift force to preserve the contact between overhead line and pantograph head. Nowadays, there are several kinds of pantographs existing, but the standards are almost the identical (Matvejevs & Matvejevs, 2011). The pantograph consists of a part of physique that come in contact with the overhead catenary and a body that supports it. The body is divided into upper frame and lower frame. The important spring acts to lift the whole pantograph upwards as shown in Fig. 1. The pantograph doesn't control the versions of the contact force by means of itself. In order to control the contact force between the pantograph and the catenary, the active pantographs with the pneumatic actuator have been developed. It used to be found via some experiments that the frame had flexibility which may want to not be omitted to control the contact force. Some high-speed rail structures are powered with the aid of electrical energy furnished to a pantograph on the train's roof from a catenary overhead. The force applied with the aid of the pantograph to the catenary is regulated to keep away from loss of contact due to immoderate transient motion. A proposed method to adjust the force makes use of a closed-loop feedback system, whereby a force, F_{up} , is utilized to the bottom of the pantograph, resulting in an output force applied to the catenary at the top. The contact between the head of the pantograph and the catenary is represented with the aid of a spring. The output force is proportional to the displacement of this spring, which is the distinction between the catenary and pantograph head vertical positions.

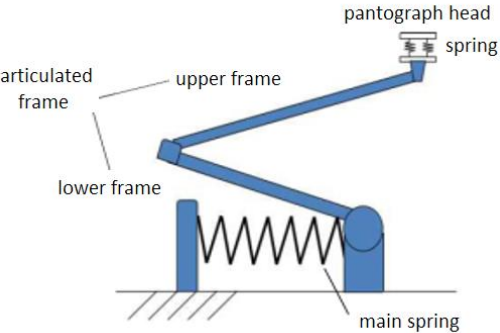

Fig. 1. Pantograph system

2.2. Catenary

The catenary usually consists of the contact wire, a continuous conduction which transfers electric powered present day to the transferring train through the pantograph, and some different supporters to aid the weight of the contact line and to keep the contact wire in a certain form at positive positions. The structure of the catenary proven in Figure 2. In general, a catenary is composed of one or two wires that make sure the strength transmission to the pantograph, and it also counts with one or two complementary wires that are charged of maintaining the horizontality of the contact wire, as found in Fig. 2.

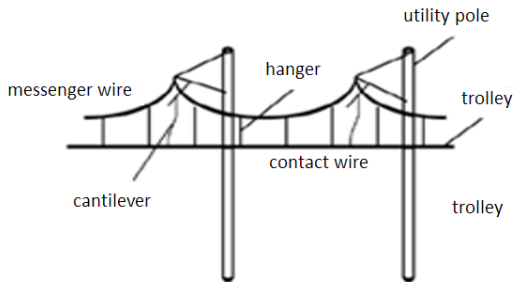

Fig. 2. Catenary system

The train is linked to the catenary system by way of pantograph which is set up on the roof of the train. The catenary has two wires, the contact wire which is connected to the pantograph and the messenger wire above the contact wire is linked together over the droppers. The pantograph catenary is targeted to transfer electric current to the train. As a contact pair is continually moving, it is necessary to maintain the contact between pantograph and catenary tight and stable.

Consider the train circumstance is continually moving, it is wanted to control the contact power varieties and not to get the contact misfortunes between the pantograph and catenary framework. The overhead contact wire and pantograph need to stay in touch with one another.

The proposed strategy to manage the power between the pantograph shoe and the electric contact utilizes a closed-loop framework, whereby a force is connected to the base of the pantograph, bringing about a yield power connected to the catenary at the top. Fig. 3, demonstrates the pantograph and catenary coupling.

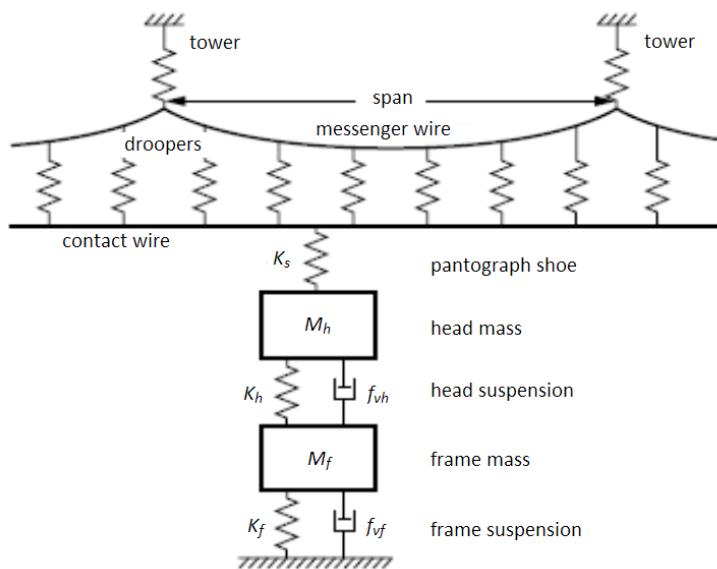

Fig. 3. Pantograph and catenary coupling system

Assuming that the overhead contact wire and the shoe on the pantograph head are linked all the time, the contact between the head of the pantograph and the catenary is represented with the aid of a spring. Output force is proportional to the displacement of the spring, which is the distinction between the catenary and pantograph head vertical positions. Let is static uplift force generated through the essential spring which is denoted as the actuator force and is the role at the top of catenary, so that the equations of movement are (Lin, Lin & Yang, 2007):

$$F_{up} - f_{vf}\dot{Y}_f - K_h(Y_f - Y_h) - f_{vh}(\dot{Y}_f - \dot{Y}_h) = M_f\ddot{Y}_f \quad (1)$$

$$K_h(Y_f - Y_h) - f_{vh}(\dot{Y}_f - \dot{Y}_h) - K_s(Y_h - Y_{cat}) = M_h\ddot{Y}_h \quad (2)$$

$$K_s Y_h - (K_s + K_f) Y_{cat} = 0 \quad (3)$$

Where M_f and M_h are frame and head masses, f_{vf} and f_{vh} are frame and head dampers coefficients, finally K_f , K_h and K_s are frame, head and spring stiffness coefficients. Take all the physical parameters from (Shudong, Jingbo & Guosheng, 2008), and these are shown in Tab. 1:

Tab.1. Physical parameters

Parameter	Value
M_f	17.2 [Kgd]
M_h	9.1 [Kg]
f_{vf}	30 [N.s/m]
f_{vh}	130 [N.s/m]
K_f	$1.535 \cdot 10^6$ [N/m]
K_h	$7 \cdot 10^3$ [N/m]
K_s	$82.3 \cdot 10^3$ [N/m]

By solving Eq. (1), Eq. (2) and Eq. (3), the transfer function is determined as (Shudong, Jingbo & Guosheng, 2008):

$$G(s) = \frac{Y_h(s) - Y_{cat}(s)}{F_{up}(s)} = \frac{0.7883(s+53.85)}{s^4 + 23.59s^3 + 9785s^2 + 81190s + 3.493 \cdot 10^6} \quad (4)$$

3. MODEL ORDER REDUCTION

As considered from Eq. (4), the order is fourth, this gives a complicated analysis and design, so that it wishes model order reduction. There many methods for this and can be classified in classical and modern (Makino et al., 2018) but in this paper can be used particle swarm optimization (PSO) technique, Which has been proposed via (Al-Awad & Al-Seady, 2020), as a result developed in hundreds of scientific papers, and utilized to many numerous problems, for instance neural networks training, information mining, signal processing, and optimum plan of experiments. PSO is a population-based method, that is, it represents the

nation of the algorithm by using a population, which is iteratively modified until a termination criterion is satisfied. In PSO algorithms, the populace $P = \{p_1, \dots, p_n\}$ of the possible options is regularly referred to as a swarm. The feasible solutions p_1, \dots, p_n are called particles. The PSO technique views the set R_d of possible options as a “space” where the particles “move”. For solving practical problems, the variety of particles is usually chosen between 10 and 50. The normal aim of the particle swarm optimization (PSO) algorithm is to solve an unconstrained minimization problem. PSO would possibly sound complicated, but it is certainly a very easy algorithm. Over a range of iterations, a group of variables have their values adjusted nearer to the member whose value is closest to the goal at any given moment. Generally there are many papers about the algorithm of PSO and how can be used to solve the issues. In this paper the integral square error criteria (ISE) is used as performance index to decrease the error between the parameters of original and reduced systems. The parameters of PSO algorithm in this work are considered as follows:

1. Inertial weight: 0.9.
2. Acceleration factors (c_1 and c_2): are (0.12) and (1.2).
3. Population size: 200.
4. Maximum iteration: 1000.

The objective function (OF) must be a minimization problem. Let us suppose that there is a problem defined is needed to be optimized by using:

$$ISE = \int_0^{\infty} [e(t)]^2 dt \quad (5)$$

After using PSO MATLAB program, it is found that the reduced function is:

$$G_r(s) = \frac{9.816 \cdot 10^{-7}s + 5.881 \cdot 10^{-5}}{0.0129s^2 + 0.1006s + 4.843} \quad (6)$$

There are no large differences between original and reduced order systems, where both have the same overshoot and settling time, Fig. 4 shows transient response of original and reduced order systems. For simplicity in design and analysis, Eq.(6) can be used instead of Eq.(4).

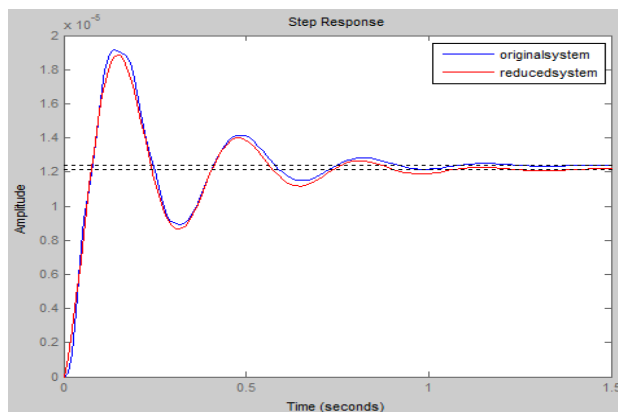

Fig. 4. Shows step response of original and reduced order system

As seen from Fig. 4 the transient specifications are almost identical. Tab. 2 shows comparison parameters between original and reduced system.

Tab. 2. Transient response parameters comparison

System	Max. overshoot Mp%	Settling time Ts (sec)	Rise time Tr (sec)	Steady-state error Ess
Original System	54.8%	0.875	0.0481	0.0000124
Reduced System	55%	0.99	0.057	0.000012

4. CONTROLLERS DESIGN METHODS

Before starting with design methods, it is necessary, to assign the requirements design. Pantograph and catenary system must be quickly response and without overshoot.

4.1. Internal mode control (IMC)

The improvement of IMC had begun on account that the late Nineteen Fifties in order to layout a most suitable feedback controller. The potential of IMC to meet most of the manipulate targets has led to their significant acceptance in the control industry. It is because, for practical utility is simple and strong to take care of the mannequin inaccuracies. The distinguishing characteristic of IMC shape is the incorporation of the system model which is in parallel with the proper system or the plant. Fig. 5 indicates the schematic graph for IMC process. The proposed controller works for specific values of the filter tuning parameters to achieve the preferred response As the IMC method is primarily based on pole zero cancellation, methods which incorporate IMC graph standards result in a desirable set point responses.

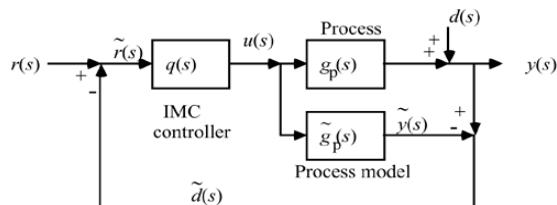

Fig. 5. Shows IMC structure

The IMC layout method consists of two steps: The first step will insure that $q(s)$ is steady and causal; the second step will require $q(s)$ to be proper. The filter transfer characteristic is to make the controller stable, causal and proper. This strong compensator (filter) performs a pivotal function in the device as it combats plant uncertainties in the system layout so that the designed manipulate system can achieve the diagram targets of strong balance and robust performance. The controller with filter is given by:

$$q(s) = \frac{G_p(s)^{-1}}{(\lambda s + 1)^n} \quad (7)$$

Where n is the order of the filter and λ is the filter time constant. The order of the filter is chosen such that is appropriate to stop immoderate differential manipulate action. The filter parameter in the plan can be chosen as a rule of thumb. Considering the order of the filter same as the plant $n = 2$, and $\lambda = 0.1, 0.01$. Fig. 6. Shows step response of the system with IMC. It appears that y_1 , with $\lambda = 0.1$, there is no $Mp\%$, but $T_s = 0.565$ sec and $T_r = 0.333$ sec, are large values. For y_2 with $\lambda = 0.01$, there is $Mp = 5.52\%$ and short values of $T_s = 0.0466$ sec, $Tr = 0.0099$ sec, so that needs more tuning to select best value of λ .

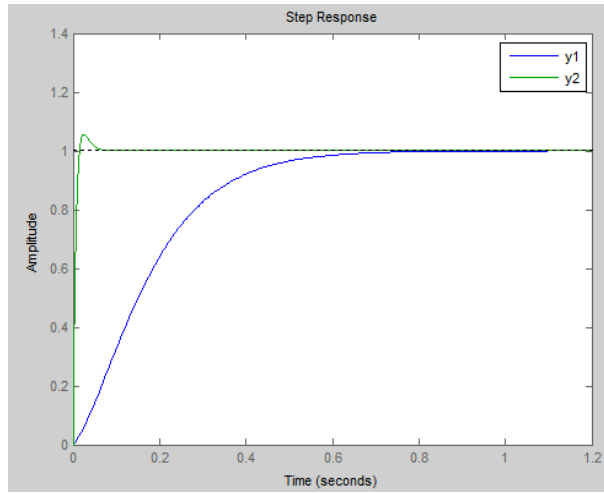

Fig. 6. Shows step response of the system with IMC with different values of λ : $\lambda=0.1$ for y_1 and $\lambda=0.01$ for y_2 .

4.2. Proposed G.A-PID controller

G.A-PID controller has been proposed for tuning PID boundaries for Eq.(6) utilizing a weighted mix of target work, specifically, integral absolute error (IAE). The G.A is an arbitrary pursuit technique that can be utilized to illuminate nonlinear arrangement of conditions and streamline complex issues. GA utilizes probabilistic progress administrators rather than deterministic principles and handles a populace of potential arrangements known as people or chromosomes that develop interactively. Every emphasis of the calculation is named as generation. The development of arrangements is mimicked through a wellness work and hereditary administrators, for example, reproduction, crossover, and mutation (Kennedy & Eberhart, 2016). Genetic algorithm as delineated in Fig. 7. is normally instated with an irregular populace. This populace is typically spoken to by a real-valued number or a double string called a chromosome. The presentation of the individual is estimated and surveyed by the goal work, which allots every individual a comparing number called its fitness. The fitness of every chromosome is surveyed and natural selection procedure is applied. In this work, the error value is utilized to survey the fitness of every chromosome.

There are three primary activities in a Genetic algorithm, reproduction, crossover, and mutation. Crossover and mutation costs can have an effect on the convergence of GA, however nothing can evaluate to the level of manipulate carried out via manipulating of the inertial weight. The greater reduce of inertial weight the greater make bigger the swarm's convergence. This type of manipulate allows finding out the price of convergence, and the level of 'stagnation' ultimately achieved. Stagnation occurs in GA when all of the individuals have the identical genetic code. In that case the gene pool is uniform, crossover has little or no impact on population and each successive generation is surely identical as the first (Haamed & Hameed, 2020).

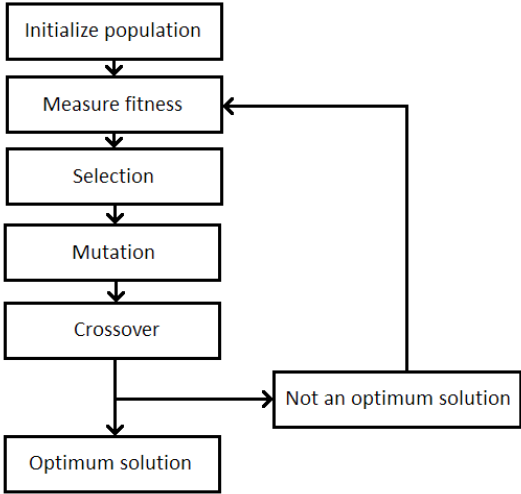

Fig. 7. Flowchart of G.A procedure

Genetic Algorithm Steps are:

1. Initialize the parameter with a population of random solutions, such as crossover rate, mutation rate, number of clusters, and number of generations. Determine the coding mode.
2. Compute and evaluate the value of the fitness function.
3. Proceed with crossover and mutation operation and make up the new cluster.
4. Repeat Step 2, till the best value is obtained.

In general, using the integrated absolute error (IAE), or the integral of squared error (ISE), or the integrated of time weighted squared error (ITSE), or the integral of time multiplied through absolute error (ITAE) is regularly employed in manage system due to the fact it can be evaluated analytically in frequency domain (Kłosowski, Klepka & Nowacka, 2018).

The four integral overall performance criteria have their personal advantages and disadvantages. In this paper, (IAE) can be used as:

$$IAE = \int_0^{\infty} |e| dt \tag{8}$$

G.A algorithm parameters are set based on trial and error as follows:

1. Maximum iteration: 500.
2. Population size: 100.
3. Encoding: binary.
4. Selection: uniform.
5. Crossover: single point.
6. Mutation: uniform.

Fig. 8. shows the block-diagram of G.A-PID controller, after many iterations can be estimated the optimal parameters tuning of PID controller, K_p , K_i , and K_d .

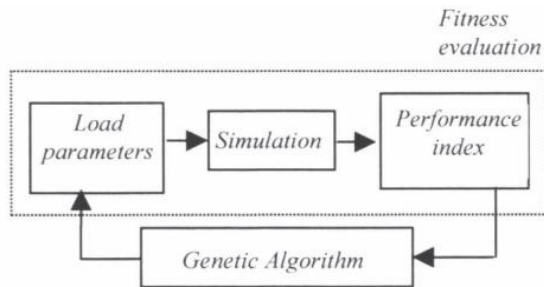

Fig. 8. Block-diagram of G.A-PID control

Fig. 9. shows step response of the system with G.A-PID controller, where $M_p = 0.876\%$, $T_s = 0.0673$ sec and $T_r = 0.0435$ sec, and these optimum values design requirements for pantograph-catenary System.

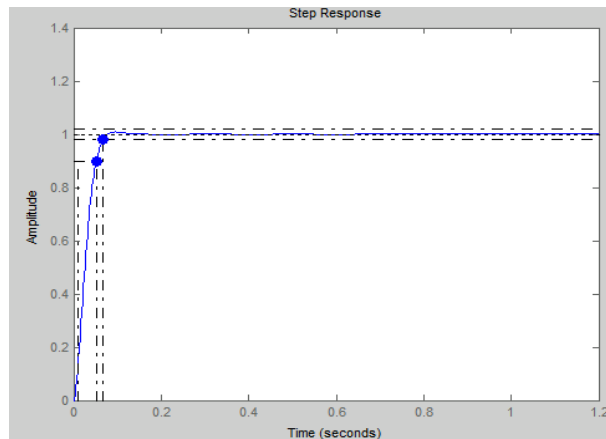

Fig. 9. Shows step response of the system with G.A-PID controller

5. RESULTS AND DISCUSSION

For the reason to assessment between the performances of all controllers and G.A-PID, it is fundamental to simulate the transient responses with recognize to settling time, maximum overshoot, rise time and steady-state error and calculate plan specifications and put it as proven in Tab. 3.

Tab.3. Comparison between all controllers' types

Controller Types	Max. overshoot Mp%	Settling time Ts (sec)	Rise time Tr (sec)	Steady-state error Ess
IMC	0	0.565	0.333	0
G.A-PID	0.876	0.0673	0.0435	0

Overall results on the numerical experiment by using MATLAB had shown that the G.A-PID controller improve the effectiveness in control performance as in Fig. 9 especially on reduction of T_s , T_r and very small M_p of pantograph-catenary system.

Performed simulations pointed out that IMC, G.A-PID approaches lead to zero steady-state error, while LQR needs prefilter to do it and it required more tuning to meet design requirements (reduce M_p , T_s).

6. CONCLUSION

In this paper, G.A-PID controller for desired input (step) is developed based on the process model. The pantograph-catenary system is considered in the simulation study in order to demonstrate the superiority of the proposed method. A closed loop response of pantograph-catenary system tuned by the proposed method is compared with the existing conventional IMC controller. Results demonstrated that the G.A-PID has a sufficient performance to control of the system within controller design criteria. It clearly shows that G.A-PID technique gives better performances than IMC controller, when compared Figs (9,6). But G.A-PID requires 32.85 seconds computational time to reach design requirements and make performance index (IAE) with low values (approach to zero).

REFERENCES

- Al-Awad, N., & Al-Seady, A. (2020). Fuzzy Controller of Model Reduction Distillation Column with Minimal Rules. *Applied Computer Science*, 16(2), 80–94. <https://doi.org/10.23743/acs-2020-14>
- Arnold, M., & Simenon, B. (2000). Pantograph and catenary dynamics: a benchmark problem and its numerical solution. *Applied Numerical Mathematics*, 34(4), 345–362. [https://doi.org/10.1016/S0168-9274\(99\)00038-0](https://doi.org/10.1016/S0168-9274(99)00038-0)
- Bartolini, G., Pisano, A., Punta, E., & Usai, E. (2003). A survey of applications of second-order sliding mode control to mechanical systems. *International Journal of Control*, 76(9–10), 875–892. <https://doi.org/10.1080/0020717031000099010>

- Chater, E., Ghani, D., Giri, F., & Haloua, M. (2015). Output feedback control of pantograph–catenary system with adaptive estimation of catenary parameters. *Journal of Modern Transportation*, 23, 252–261. <https://doi.org/10.1007/s40534-015-0085-z>
- Giovanelli, D., & Farella, E. (2016). Force Sensing Resistor and Evaluation of Technology for Wearable Body Pressure Sensing. *Journal of Sensors*, 3, 9391850. <https://doi.org/10.1155/2016/9391850>
- Haamed, R., & Hameed, E. (2020). Controlling the Mean Arterial Pressure by Modified Model Reference Adaptive Controller Based on Two Optimization Algorithms. *Applied Computer Science*, 16(2), 53–67. <https://doi.org/10.23743/acs-2020-12>
- Kennedy, J., & Eberhart, R. (2016). Particle swarm optimization. In *IEEE International Conference on Neural Networks*, (vol. 4, pp. 1942–1948). IEEE. <https://doi.org/10.1109/ICNN.1995.488968>
- Kłosowski, G., Klepka, T., & Nowacka, A. (2018). Neural Controller for the Selection of Recycled Components in Polymer-Gypsum Mortars. *Applied Computer Science*, 14(2), 48–59. <https://doi.org/10.23743/acs-2018-12>
- Lin, Y., Lin, C., & Yang, C. (2007). Robust active vibration control for rail vehicle pantograph. *IEEE transactions on vehicular technology*, 56(4), 1994–2004. <https://doi.org/10.1109/TVT.2007.897246>
- Liu, R., Qian, C., Liu, S., & Jin, Y.-F. (2016). State feedback control design for Boolean networks. *BMC Systems Biology*, 10, 70. <https://doi.org/10.1186/s12918-016-0314-z>
- Makino, T., Yoshida, K., Seto, S., & Makino, K. (2018). Running test on current collector with contact force controller for high-speed railway. *JSME International Journal Series C*, 40(4), 671–680. <https://doi.org/10.1299/jsmec.40.671>
- Matvejevs, An., & Matvejevs, Al. (2011). Optimal Control of Pantograph-Catenary System Based on Parametric Identification. Scientific Journal of Riga Technical University Computer Science. *Information Technology and Management Science*, 49.
- O'Connor, D., Eppinger, S., Seering, W., & Wormley, D. (1997). Active control of a high-speed pantograph. *Journal of Dynamic Systems, Measurement and Control*, 119(1), 1–4. <https://doi.org/10.1115/1.2801209>
- Pisano, A., & Usai, E. (2008). Contact force regulation in wire-actuated pantographs via variable structure control and frequency-domain techniques. *International Journal of Control*, 81(11), 1747–1762. <https://doi.org/10.1080/00207170701874473>
- Pourzeynali, S., Lavasani, H.H., & Modarayi, A.H. (2007). Active control of high rise building structures using fuzzy logic and genetic Algorithms. *Engineering Structures*, 29(3), 346–357. <https://doi.org/10.1016/j.engstruct.2006.04.015>
- Shudong, W., Jingbo, G., & Guosheng, G. (2008). Research of the active control for high-speed train pantograph. In *IEEE International Conference on Cybernetics and Intelligent Systems* (pp. 749–753). IEEE. <https://doi.org/10.1109/ICCIS.2008.4670754>