

DOI: 10.5604/01.3001.0009.5184

SOFTWARE TOOL AND PERIPHERALS OF SYSTEM FOR MEASURING OF INTRA-ABDOMINAL PRESSURE

Michal Jurčišin, Slavomír Kardoš

Technical University of Kosice, Department of Technologies in Electronics, Kosice, Slovakia

Abstract. The article deals with the software tool design and its features implementation into automation measuring system of intra-abdominal pressure. Measurement system consists of peripherals controlled by electronics connected to computer with developed software. Software was used for pressure sensor optimization implemented into measurement system as well as whole system testing and its evaluation. Pressure sensors consist of glass tube with electrodes created by thin film technology. The article also deals with software possibilities and its application in testing process.

Keywords: intra-abdominal pressure, monitoring software, capacitive pressure sensor, sterile valve

OPROGRAMOWANIE I URZĄDZENIA PERYFERYJNE SYSTEMU DO POMIARU CIŚNIENIA W JAMIE BRZUSZNEJ

Streszczenie. Artykuł dotyczy projektowania oprogramowania narzędziowego i jego zastosowania w systemie zautomatyzowanego pomiaru ciśnienia w jamie brzusznej. Układ pomiarowy składa się z urządzeń sterowanych elektronicznie i podłączonych do komputera oraz zaprojektowanego oprogramowania. Oprogramowanie zostało wykorzystane do optymalizacji czujnika ciśnienia zastosowanego w systemie pomiarowym, jak również do testowania całego systemu i jego oceny. Czujnik ciśnienia składa się z rurki szklanej z elektrodami utworzonymi w technologii cienkowarstwowej. W artykule opisano również możliwości oprogramowania i jego zastosowanie w procesie testowania.

Słowa kluczowe: ciśnienie wewnątrzbrzuszne, oprogramowanie monitorujące, pojemnościowy czujnik ciśnienia, zawór sterylny

Introduction

Abdominal compartment syndrome (AbCS) is caused by the increase of intra-abdominal pressure (IAP) from tissue tumescence or from accumulation of free liquid in abdominal cavity. When it is not timely diagnosed and it is not cured, it may result in multi-organ collapse and death [3]. For measuring of IAP the direct and indirect methods exist. Indirect method of IAP measurement is based on Foley catheter inserted inside urinary bladder (with corresponding intravesical pressure). This method is based on the fact that urinary bladder works as a passive transmitter IAP on internal water filling. Empty urinary bladder is filled with 20–50 ml of sterile saline via catheter [4].

1. Concept of automation system for intra-abdominal pressure measurement

For using of developed automation measurement system in clinical praxis it is necessary to state the basic requirements. Due to application field it is necessary to ensure sterility of the system during measurement. Distribution of intravesical pressure grades used in clinical practice is as follows: 1) 1.59 kPa – 1.99 kPa, 2) 2.13 kPa – 2.66 kPa, 3) 2.79 kPa – 3.33 kPa, 4) > 3.33 kPa. In the second grade i.e. at a pressure of 2.66 kPa it is necessary to decompress the abdominal cavity what is reached by cutting the abdominal wall and keep it opened. Automation system should have better precision than 0.098 kPa. Measurement of IAP is carried out at one hour intervals with the following procedure:

- system preparation for measurement – filling of bladder and system tubes with exact volume of saline,
- realization of measurement in the time interval of several minutes,
- drying of system.

2. Capacitive pressure sensor

For realization of pressure sensor the thin film technology was used. Capacitive pressure sensors (Fig. 1) were realized by glass tubes with 4 – 9 mm inner diameter. On the outer surface of the glass tube the two thin-film electrodes was deposited by vapor deposition. As a material for deposition the copper was used. As dielectric of capacitive sensor the saline was used (0.9% NaCl aqueous solution).

Parameters of used glass tubes were analyzed in [1]. Measured capacity varied depending on the tube diameter in the range of 11.7 pF – 25 pF without dielectric corresponding to the pressure 0 kPa, and 14.3 – 132 pF with a dielectric at 300 mm height corresponding to the pressure 2.94 kPa according to [1]. Advantage of proposed sensor solution is elimination of air bubbles inside the system created during process of filling and emptying of system. Figure 1 show practical realization of pressure sensor.

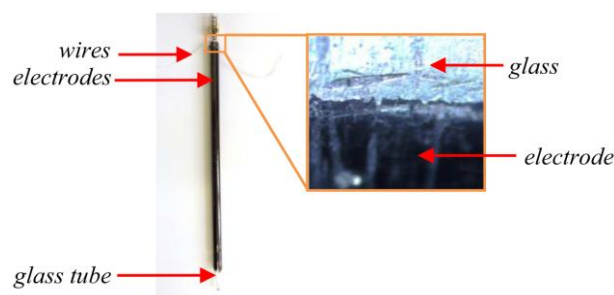

Fig. 1. Practical realization of pressure sensor

3. Description of automation system for measurement of intra-abdominal pressure

Block diagram of developed automation system for measuring of IAP by noninvasive method is shown on Fig. 2 and was described in [1].

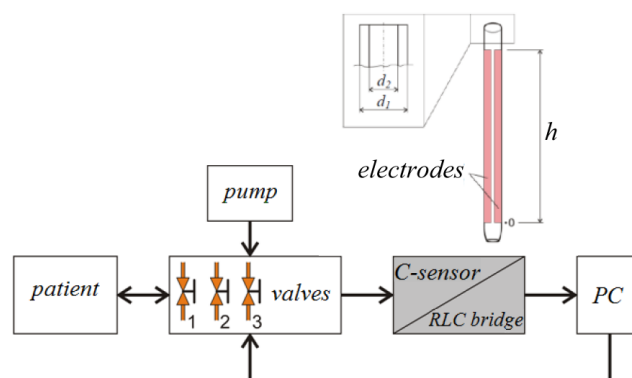

Fig. 2. Block diagram of automation measurement system

Operation of valves and infusion pump is provided by control electronics (Fig. 3) connected to PC on the basis of program. Output ports of microprocessor control three valves and step motor of infusion pump of measurement system. Control electronics is realized on PCB by Through Hole Technology and SMT. Basic part of PCB is CPU DS89C430 with external clock crystal and support circuit for in-system programming. Connection to PC is provided by IC MAX232 which converts the signal to serial transmission via RS232 port. Used CPU enables transmission through two independent serial ports. First serial port is used for connection to PC and second port is reserved for future connection to infusion pump. For peripherals control the input/output ports of microprocessor are used. Valves are controlled by first port and step motor of infusion pump by second independent port. During monitoring process is necessary to ensure connection of control electronics and RLC meter Motech MT 4090 to computer. Both devices are equipped with RS232 communication port. Today's computers are not equipped with RS232 port. Due to this reason was necessary to solve conversion of signal to USB protocol. This conversion was ensured by conversion connector from ST-Lab. Conversion connector consists of one USB port and two RS232 ports. After driver installation to PC the RS232 ports are fully available for use.

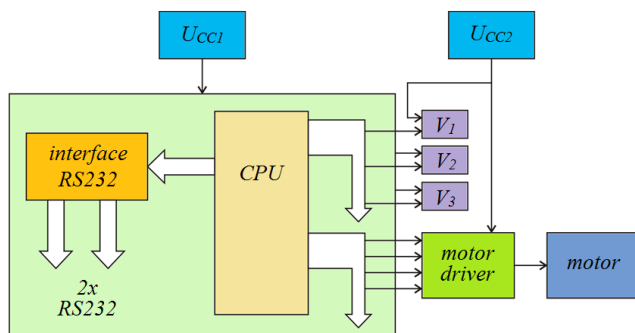

Fig. 3. Blok diagram of automation measurement system control electronics

Realization of peripherals

Peripherals of measurement system controlled by microprocessor consist of three valves and medical infusion pump. Due to medical purpose of the system it was necessary to solve sterility issue. For realization of valves the electronically controlled servomotors were used. This solution enables controlling the position of throttle by rotation of servomotor arm. Rotation arm press the tubes what change its flow rate. For practical realization of automation system two types of servomotors with different torque were used due to different types of tubes. In case of thick walled tubes the servomotor was used with torque up to 2 Nm. Practical realization of valve is shown on Fig. 4.

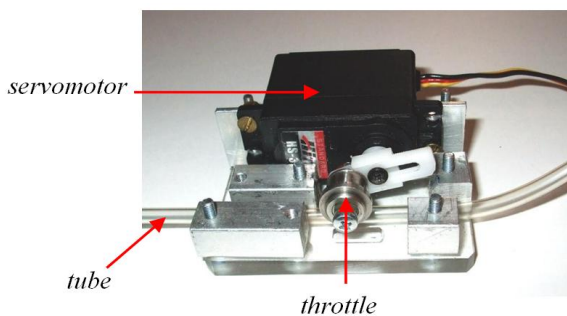

Fig. 4. Practical realization of valves

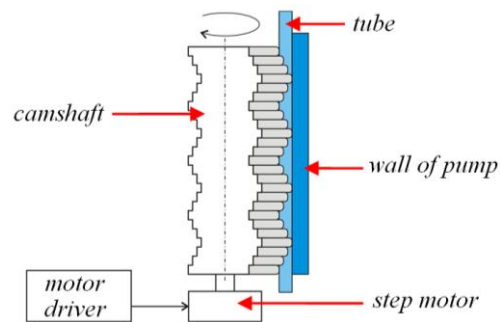

Fig. 5. Principle of infusion pump

Other peripheral connected to control electronics was step motor of medical infusion pump which should pump precise volume of liquid to the system. Infusion pump was modified for purposes of automation system and step motor was driven by motor driver according control electronics commands. Principle of infusion controlled parts of infusion pump is shown on Fig. 5. Camshaft rotation causes flow of liquid inside the tube without any affect to sterility of the system.

4. Monitoring software for automation measurement system

For simple control of automation measurement system the monitoring software was developed. Monitoring software provide graphical representation of measured pressure respectively sensor capacitance. Other features of created application are the archiving of measured results with possibility of data re-viewing and control of measurement system peripherals. Graphic user interface of monitoring software is shown on Fig. 6.

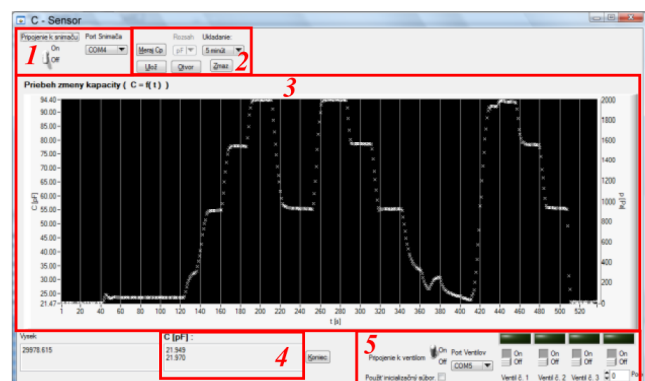

Fig. 6. Graphic user interface of software for monitoring and control of automation system for measurement of intra-abdominal pressure

User interface of monitoring software consists of following parts (Fig. 6):

- 1 – connection to capacitance measuring instrument – before connection to capacitance measuring instrument it is possible to make necessary settings (port number),
- 2 – saving and loading of archived files – possibility of measured data saving, loading of archived files,
- 3 – graphical representation of measured data – displaying of measured capacity (left Y axis), resp. pressure (right Y axis) in time dependence (X axis). Time axis is dynamically adjusted.
- 4 – list of measured data in text format – at this part the text list of measured results is displayed. The list is updated after every measurement.
- 5 – connection settings and buttons for control of valves and pump of automation measurement system – enables the connection to peripheral parts of system, peripherals can be controlled manually or automatically.

4.1. Archiving of measured data

Created monitoring software provides manual and automatic archiving of measured data. Before connection of application to RLC meter for capacity (pressure) measurement the period of continuous saving can be set. After elapse of preset time period the automatic data saving occurs. Other possibility for data archiving is manual saving. Saved files can be edited as needed. Structure of saved file is shown on Fig. 7.

First row of file contains information about time and date of archiving. Next item is header of table. First column of table is number of seconds from the beginning of measurement. Second column contains capacity value for corresponding time.

11:00:32	14. 12. 2012
t [s]	Cp [pF]
1	59.605
2	59.625
3	59.585
4	59.603
5	59.588
6	59.619
7	59.614
8	59.556
9	59.547
10	59.622

Fig. 7. Example of saved file

4.2. Control of automation measurement system peripherals

Peripherals of measurement system can be controlled manually or automatically. Before connection of monitoring software to the peripherals it is necessary to set manual or fully automatic control. Indicator of automatic control is check box „Use INI file“. In case of manual control the user can directly control the peripherals using buttons according Figure 8.

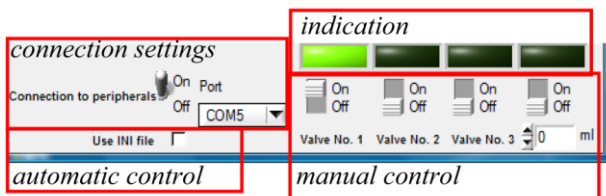

Fig. 8. Controls for handling of peripherals

Peripherals can be controlled by four switches. First three switches control valves. Fourth switch controls the infusion pump. Above each switch is located indicator which determines peripheral's state. In case of automatic control it is not possible to change switches state resp. peripherals state by pressing it. Automatic control of peripherals uses initialization file. Initialization file structure is shown on Fig. 9.

t	U1	U2	U3	PUMP
[m:s]				
00:01	0	0	0	0
00:02	0	0	1	0
00:03	0	0	1	5
00:15	1	1	0	0
00:16	1	1	0	10
00:45	1	1	0	0
00:46	1	1	1	0
00:47	1	0	1	27
01:57	1	0	0	0
09:59	0	0	0	0
19:59	0	0	0	0
EOF				

Fig. 9. Structure of initialization file for automatic control of system peripherals

The file consists of five columns. First column represents the time from beginning of actual measurement cycle. At the time defined by first column, peripherals state is changed according to state of other columns. Columns 2, 3 and 4 define states of valves. Column number five defines volume (in ml) of saline which has to be injected into the system. Initialization file shown on Fig. 9 presets 20 minutes measurement cycle. During first 2 minutes the system initialization is realized. Within next 8 minutes the measurement is realized. Subsequently, the system is drained until the end of the measurement cycle. After completion of the measurement cycle the procedure is automatically started from the beginning of initialization file.

5. Monitoring software implemented in testing process

5.1. Testing of capacitive pressure sensors

Using developed monitoring software the tests was realized which allow creation of calibration courses of tested capacitive sensors realized on glass tubes with different diameters. Results of tests reached from created monitoring application also enable to state the static and dynamic parameters presented in [1].

Capacity changes course of tested glass tube with spontaneous decrease of liquid level is shown on Fig. 10. In case of glass tube number 1 (Fig. 10), during 460 s time interval of capacity stabilization to constant value occurs. Capacity value after stabilization was not the same as value C_{MIN} . Residual capacity ΔC was approximately 0.5 pF. Tested glass tube showed changes of C_{MIN} and C_{MAX} in several measurements. By the same procedure the parameters were reached for other glass tubes presented in [1].

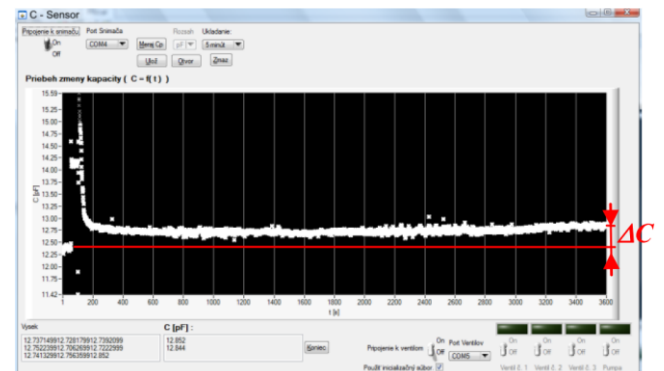

Fig. 10. Capacity changes course of capacitive pressure sensor with spontaneous decrease of liquid level (measurement 3600 s time interval)

5.2. Testing of automation measurement system

For control of automation measurement system the software was modified to provide information about value of measured pressure. Conversion of measured capacity to pressure value was based on obtained calibration curves presented in [1]. During the tests automatic data archiving and also automatic control of valves and pump of measurement system was used. One of the tests realized on measurement system was long term test for verifying stability of system as well as stability of monitoring software. Measurement system was tested for the period of 8 hours with constant pressure load with measurement cycle period of 3600 s (Fig. 11). The mean square error calculated from the measured values is +0.011 kPa. This value is acceptable for medical praxis. This measurement confirms that measurement system is functional in long term and no leakage was proven.

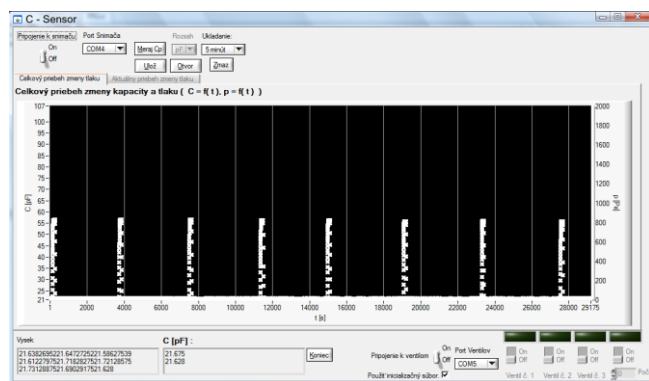

Fig. 11. Long term stability of pressure values measurement

6. Conclusion

This article provide short summary of possibilities of software tool developed for automated system for measuring of intra-abdominal pressure. Created software make easier to find the calibration curves of pressure sensors created on glass tubes using thin film technology. These measurements enable to consider the suitable sensor parameters. Sensor with suitable parameters was implemented into developed automation system. Automation system was tested in laboratory conditions. For tests evaluation the monitoring software was used, which enables archiving of measured data, and also enables control of automation system peripherals manually, and automatically. Whole system will simplify measurement process in focus of medical staff and eliminate the human mistakes. In the first step the sterility of system and measurement via capacitive sensor was solved. (Project VEGA 1/0059/12)

References

- [1] Jurčišin M., Slosarčík S., Cabúk P.: Automation measurement of intra-abdominal pressure, *Advanced Numerical Modelling*, Zielona Góra, August, 2011.
- [2] Kron I. L., Harman P. K., Nolan S. P.: The measurement of intra-abdominal pressure as a criterion for abdominal re-exploration, *Ann Surg*, 1984.
- [3] Molčányi T., Magdo J., Raši R., Cestická T., Michlík J., Molčányiová A.: Možnosti ošetrovania laparostomie pri abdominálnom kompartment syndrome, *Novinky v anesteziológii, intenzívnej medicíne a algeziológii*, Prešov, Náuka, 2005, 122–127.
- [4] Obeid F., et al.: Increases in intra-abdominal pressure affect pulmonary compliance, *Arch Surg*, 130 (5), 1995, 544–547, discussion 547–548.

Ph.D. Michal Jurčišin

e-mail: michal.jurcisin@tuke.sk

Michal Jurčišin was graduated Master study (Ing.) at the Department of Technologies in Electronics at Technical University in Košice in field of materials and technologies. In 2009 he becomes a Ph.D. student. His scientific research is aimed at application of pressure sensors. In June, 2013, he defended his Ph.D. thesis in field of bioelectronics.



Ph.D. Slavomír Kardoš

e-mail: slavomir.kardos@tuke.sk

Mr. Ing. Slavomír Kardoš, Ph.D. started his Ph.D. study at the department after defending his diploma thesis "Assembly and Interconnection Techniques in Microelectronics" in 1998. The topic of his next work is oriented to interconnection techniques and fine thick film technologies. In 2007, he defended his Ph.D. thesis in the field of capacitive position sensors.



otrzymano/received: 13.03.2014

przyjęto do druku/accepted: 30.10.2016