

DOI: 10.5604/01.3001.0010.5209

SIMULATION AND COMPARISON OF SELECTED FAST CHARGER TOPOLOGIES

Dariusz Zieliński¹, Mikhail Tokovarov²¹Lublin University of Technology, Department of Electrical Drives and Machines, ²Lublin University of Technology, Institute of Computer Science

Abstract. The article reviews the role of fast chargers in swiftly developing area of electrical energy storage devices. Energy efficient techniques implemented in fast chargers are shown, world standard requirements are mentioned. The models of the two topologies of the greatest interest: soft switched rectifier with diodes at the secondary side and synchronous rectifier are carried out and the results of simulations are presented. Higher efficiency of synchronous rectifier is proven.

Keywords: synchronous rectifier, comparison, fast charger, supercapacitor

SYMULACJA ORAZ PORÓWNANIE WYBRANYCH TOPOLOGII SZYBKICH ŁADOWAREK

Streszczenie. Artykuł jest poświęcony opisaniu roli, którą spełniają szybkie ładowarki w dynamicznie rozwijającej się branży zasobników energii elektrycznej. Pokazane są technologie wysokiej sprawności stosowane w szybkich ładowarkach. Wspomniane są również wymogi standardów światowych. Wykonane zostały modele dwóch najbardziej perspektywicznych topologii: miękko przełączany prostownik z diodami po stronie wtórnej oraz prostownik synchroniczny, wyniki przeprowadzonych symulacji zostały przeanalizowane. Udowodniona została wyższa sprawność prostownika synchronicznego.

Słowa kluczowe: prostownik synchroniczny, porównanie, ładowarka szybka, superkondensator

Introduction

As electric energy becomes used wider in various fields of technique, electrical energy storage devices gain more and more importance. One of swiftly developing areas is electric driven vehicles. Traction requires use of batteries of very high and clearly specified parameters. In terms of compliance with these requirements Li-Ion batteries seem to be fairly feasible. Due to their high power density, long life cycle, high energy-to-mass ratio, comparatively low cost and high standard of safety which is vital for use in private and public transport they appear to be perfect for application as power source for vehicles. The main weak place of Li-Ion batteries is low charging rate, which can be explained, firstly, by hazard of faster exhaustion of battery components and, secondly, by danger of fire and even explosion in case of appearance of local over-potentials and overheating. Considering actual trends in modern traction vehicles this slight disadvantage becomes more significant. One of promising solution is to use supercapacitors. It is clear that due to its major disadvantage, i.e. slow charging, Li-Ion do not meet critical requirement of the fast charging vehicle concept. Although a supercapacitor has less electric capacity, its power density is much higher. Supercapacitors can maintain current with the magnitude up to 600 A for a short time [1]. It means that a supercapacitor can both discharge, releasing energy when the application has to perform with a high peak power, as well as be charged by current of the high value mentioned herein above, which means that it requires significantly less time to accumulate full charge [1].

Comparing to other types of electric energy storage devices supercapacitors have excellent charging rate [1], but the capability of being charged fast is only one side of the problem. On the other hand a device which could provide energy at corresponding rate is required. The energy should be transferred with possibly lowest losses.

1. Charging devices standardization

In order to standardize and to get the design and the characteristics of rectifiers in compliance with requirements of health, safety, environment and energy efficiency norms various special standards have been elaborated. CHAdeMO is the standard regulating main parameters of a fast charger. In accordance with this standard a rectifier used in fast charger should fulfill conditions in terms of current, power, efficiency, safety and compatibility [6].

The CHAdeMO standards include six main points, they are listed herein below with short descriptions as follows:

- 1) Safety first [9] – user's safety is of highest priority, which is ensured by use of the following measures:
 - the pilot signals and data signals via CAN are exclusive what allows to duplicate the communication thus preventing false operation, as action is defined by signals AND condition and stop - by OR;
 - the structure of interlocking hardware is designed in such a way that a coupler can never be disconnected from the inlet during the process of charging, so no active electricity can come to the exposed terminal parts when the coupler is disconnected;
 - electrical circuit design and insulation checking procedure should prevent any electricity leakage.
- 2) User-friendly connector inlet [10]:
 - a connecting device should consist of two parts: connector of the charger side and an inlet at the side of a vehicle.
 - the design should ensure the optimal combination of ergonomic shape, simplicity in use and good charging capabilities;
 - the design of the connecting interface of different power levels should differ in terms of shape in order to avoid misuse.
 - similarly the shape of AC and DC inlets should be different;
 - The Figure 1 presents the example of various charging connectors and inlets complying with CHAdeMO standards.

	IEC DC Charging Systems			
	System A CHAdeMO (Japan)	System B GB/T (PRC)	System C COMBO1 (US) COMBO2 (DE)	
Connector				
Vehicle Inlet				
Communication Protocol	CAN		PLC	

Fig. 1. Types of connectors as per CHAdeMO standard [6]

- 3) Future-proof flexibility [12]:
 - all the newly designed chargers and connectors are required to be in compatible with older versions;
 - the CHAdeMO standards provide only critical requirements in terms of safety, efficiency, power etc, but do not restrict implementations of various useful improvements such as

navigation, telematics system as well as more convenient payment methods and so on;

- 4) CAN communication [13]: nowadays CAN is applied as the preferred onboard communication network for all types of electric vehicles as well as for inner combustion engine cars, hence it is considered as the most reliable and proven solution, the CAN protocol is used widely so it has been decided to use that known and trusted protocol to ensure the highest safety and reliability for the customers.
- 5) Optimal output power [14]: output power of a fast charger should have such a value that would ensure the optimal fulfilling of two controversial conditions: possibly shorter charging time on the one hand and lower cost of securing the maximum power. Since making time shorter incurs not only higher cost of a charger but also higher cost of connecting to grid, the solution is a typical tradeoff: after evaluating the optimal output power it has been decided to set its mean value at 50 kW.
- 6) Compatibility with a smart grid [14]: high level of communication and intelligence should be implemented in order to allow the charger to stop charging process in case if it pushes demand beyond acceptable supply capacity and overstrains the grid.

As an example of a fast charger complying with the requirements of CHAdeMO Terra 51 fast charging station by ABB inc. is presented [7]. The parameters of the charging station are presented in Table 1.

According to the said requirements we propose use of a phase-shifted full bridge DC/DC converter with synchronous rectification. Herein we present comparison of two rectifiers one of which is a synchronous rectifier.



Fig. 2. Terra 51 fast charging station [7]

Table 1. Terra 51 fast charging station parameters [7]

Input	
AC power connection	3P+PE
Input voltage range	480 V _{AC} ± 10%
Nominal input voltage	480 V _{AC}
Nominal input current	70 A
	32 A - 70 A (Software limit option)
Nominal input power	55kVA
	22kVA - 55kVA (Software limit option)
Input frequency	60 Hz
Power factor (full load)	>0.98
Efficiency	> 92% at nominal output power
Maximum output power	50 kW
Maximum output current	120 A
Output voltage range	50-500 V
Output over-current protection	Yes
Output short-circuit protection	Yes
DC connection standard	CHAdeMO compliant
DC cable length	15 ft standard
DC plug type	JEVS G105
RFID system	13.56 MHz ISO 14443A
Network connection	GSM/UMTS modem 10/100 Base-T Ethernet

2. Theoretical background

In terms of the rectification method used in a rectifier it can be classified as controlled and uncontrolled [2]. Historically the first is uncontrolled rectification, as it can be understood from its name this method is based on the use of uncontrolled semiconductors such as diodes. There are various types of diodes used in uncontrolled rectification, some of them, such as Schottky diodes can present quite good parameters, for example: quick action, stable operation, low voltage drop, they are robust and the devices designed on the basis of diodes are cheaper and comparatively less complicated and do not require developing sophisticated control methods [2]. Along with that it can be said that they cause power losses that cannot be eliminated. But use of the other rectification technique allows us to deal with that kind of power losses. This technique is called controlled or active rectification. The idea is to use MOSFET transistors which have less resistance in ON-state, so the conducting losses can be reduced significantly through replacing diodes with MOSFETS which are switched on and off in proper moments.

Efficiency of a rectifier can be expressed as follows [3]:

$$\eta = \frac{P_o}{P_o + \Delta P_s + \Delta P_c} \quad (1)$$

where P_o is the output power of the rectifier,

ΔP_s – switching losses (in case if active or rectifier is used)

ΔP_c – conduction losses

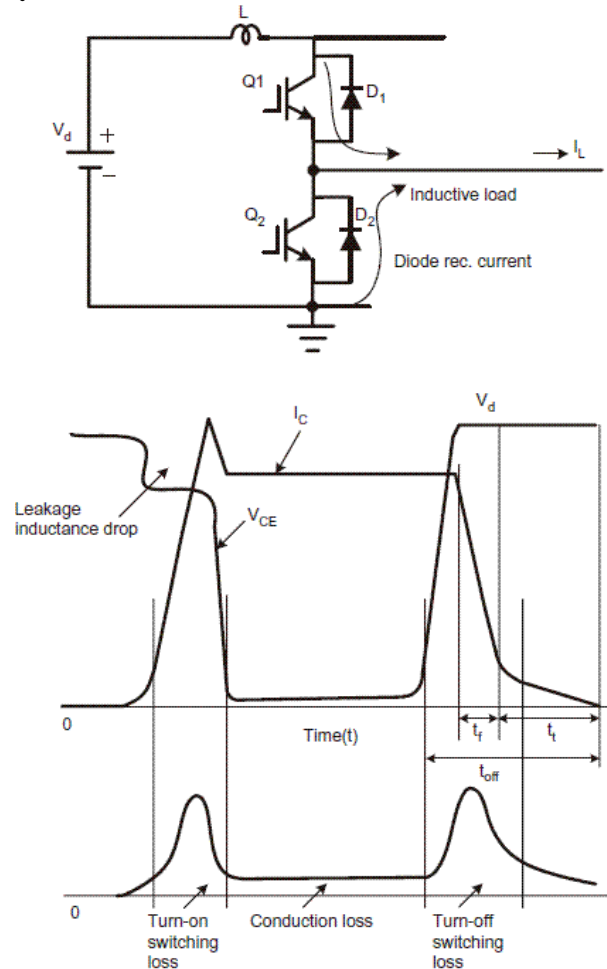

Fig. 3. Switching losses [5]

The losses mentioned herein above can be described as follows [4]:

- conduction losses, that appear due to power dissipation, during steady state of conduction, these kind of losses cannot be removed completely as every material has its own resistive characteristics and even though resistive losses theoretically may be eliminated through the use of superconductors, some

semiconductor elements such as diodes have constant voltage drop, that can result in significant energy losses;

- switching losses: this type of losses is the attribute of controlled method of rectification. This kind of losses appears as a result of so-called hard switching. The explanation is presented on the Figure 3. As it is clearly known the magnitude of power dissipating on an element of an electric circuit can be calculated as a product of current and voltage. During any steady state one of these two parameters value is very low, so the power losses being the product of voltage and current are very low as well. On the other hand significant power losses during unsteady phase can occur [4].

3. Soft switching technique description

So in order to reduce the abovementioned losses the technique called "soft switching" is used [4]. The idea of the technique is based on the use of parasitic capacities of a MOSFET and thoroughly adjusted timing of MOSFET gates control. The Figure 4 herein below presenting illustrates the idea of soft switching.

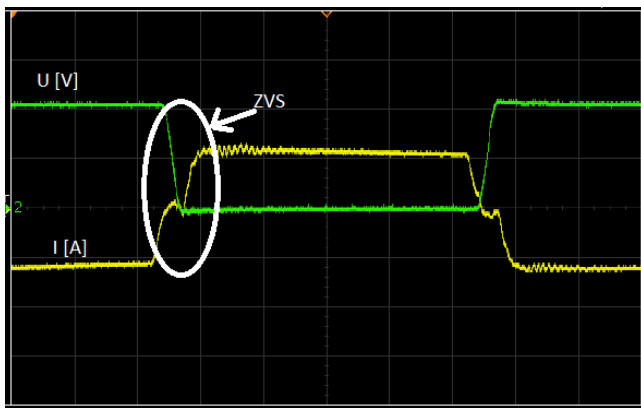
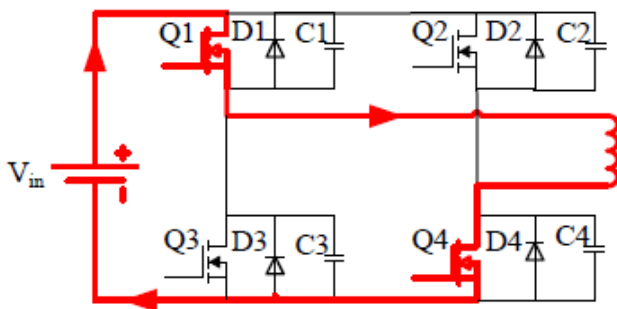
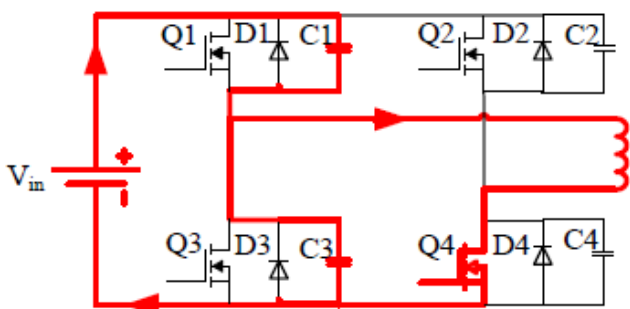

Fig. 4. The example of soft switching technique (ZVS) [4]

As it can be seen from the Figure 2, the current does not start to flow before the voltage reaches zero value. Below the one half of a cycle of a full bridge inverter is presented [4]:



Stage 1: the current flows through the transistors No. 1 and 4.



Stage 2: the transistor No. 1 is switched off, so the energy accumulated in the inductance of the transformer charges the parasitic capacitance of the transistor No. 1 and discharges the

capacitance of the transistor No. 3 preparing the conditions for ZVS of the transistor No. 3.

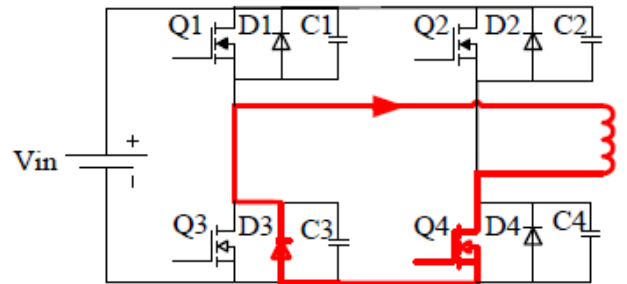

Stage 3: when the parasitic capacitance of the transistor 3 is charged hence the voltage across the transistor reaches zero value the body diode of the transistor conducts the current caused by the energy being released from the leakage and magnetic inductance of the transformer, the freewheeling stage begins, all the conditions for the transistor No. 3 ZVS are fulfilled.

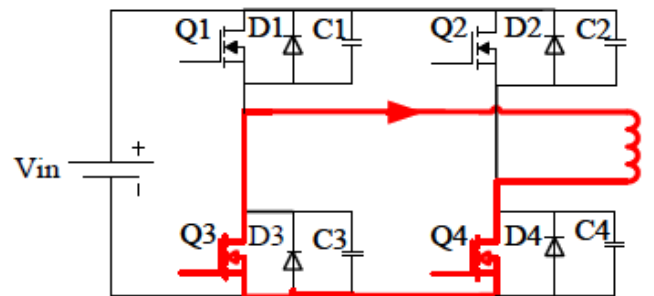

Stage 4: The transistor No. 3 is switched on, the current keeps freewheeling through the transistors.

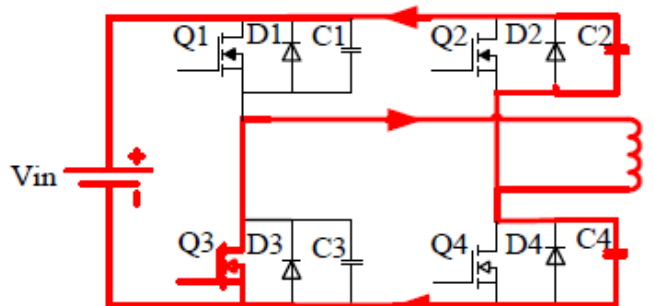

Stage 5: The transistor No. 4 is switched off. The current that was freewheeling through the MOSFETs Nos. 3 and 4 charges the parasitic capacity of the transistor No. 4 and discharges the capacity of the MOSFET No. 4, making the MOSFET No. 2 ready to be switched on with ZVS.

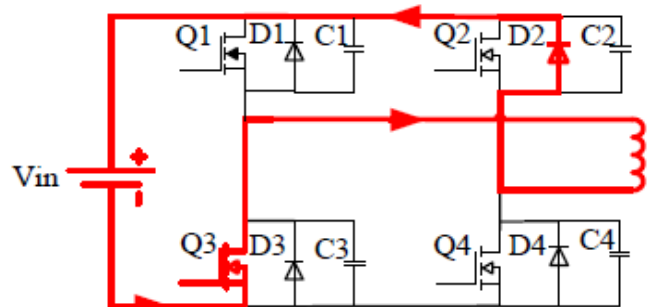

Stage 6: After the capacity of the transistor No. 2 is discharged, i.e. the voltage across it reaches zero value, the body diode conducts the current caused the energy being released from the leakage and magnetic inductance of the transformer. The MOSFET No. 2 is ready to be switched on softly.

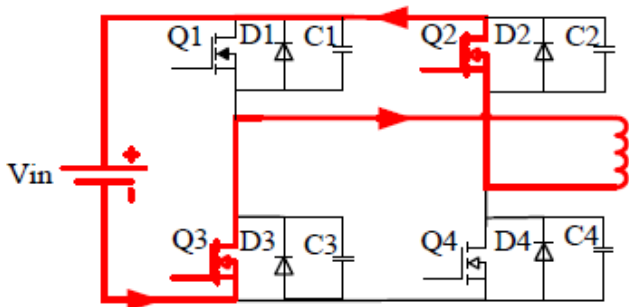

Stage 7: the MOSFET No. 2 is switched on, the current in transformer flows in the reversed direction. The second part of the cycle is identical to the presented, with the only difference: the order of the stages is reversed.

But the parameters of the elements themselves are not the only important thing, along with them timing should be taken into account.

4. Model description

In this part the comparison of two rectifier designs is presented. Both of them are implemented with the use of ZVZCS, so their primary stages use MOSFETs being switched in accordance with "soft-switching" strategy, but the first one is a mixed rectifier(MR), i.e. its secondary stage (AC/DC convertor) is based on diodes, while the second rectifier is a fully synchronous rectifier(SR), it's secondary stage use MOSFETs as well as primary.

The models have the following parameters:

Table 1. The model parameters

Parameter No.	Parameter	Parameter symbol	Value	Unit
1	Switching frequency	f	20	kHz
2	Nominal power	Pnin	1200	W
3	Nominal input voltage	Unin	500	V
4	Nominal input current	Inin	2,5	A
5	Nominal output voltage	Unout	20	V
6	Nominal output current	Inout	60	A
7	MOSFET parasitic capacity	Cmos	6	nF
8	Transformer leakage inductance	Llk	50	μH
9	Output filter inductance	Lf	15	μH
10	Output capacitor capacitance	Cf	14	mF

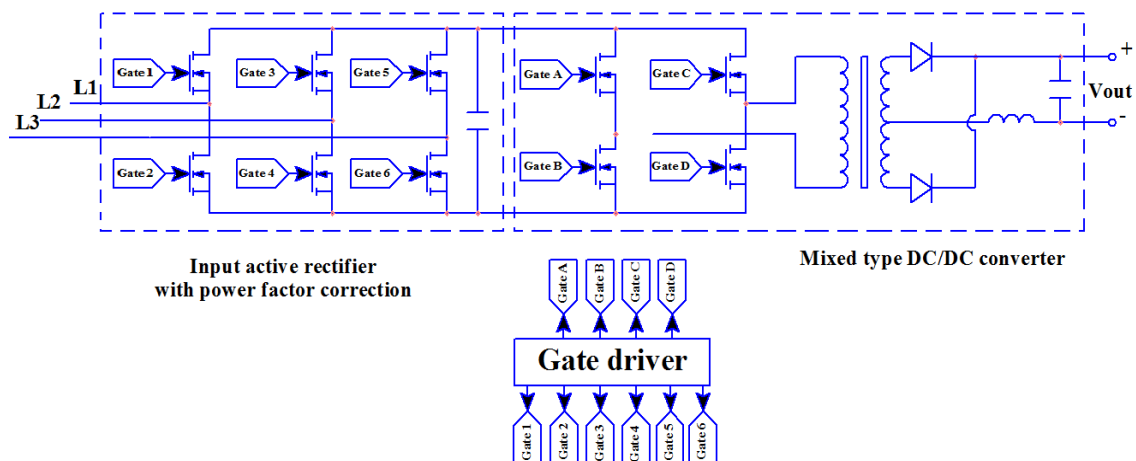

Fig. 5. Proposed design of a fast battery charger with the use of diodes at the secondary side [14]

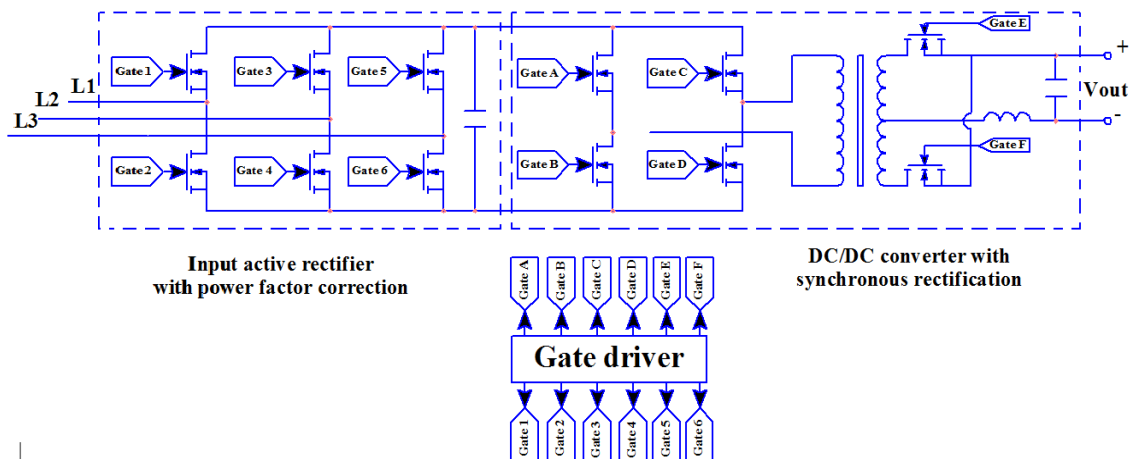

Fig. 6. The design of a mixed type fast battery charger with the use of synchronous rectification [13]

5. Efficiency evaluation method description

As it is known, the instantaneous input power can be calculated as the product of voltage and current magnitudes at the DC-bus. The instantaneous output power can be obtained as a product of output voltage and current values. In general efficiency can be calculated as [1]:

$$\eta = \frac{P_{out}}{P_{in}} \tag{2}$$

But instantaneous power approach cannot be applied for efficiency evaluation as P_{in} can change significantly for a short moment, especially during the start up period, because of charging capacities and inductances, the other method should be used. This method is based on periodical calculation of efficiency, so it changes not continuously, but discretely. So actually the efficiency per a calculation period is calculated as the ratio of output and input energy. The following scheme has been used to measure the efficiency of rectifier model on Figure 7.

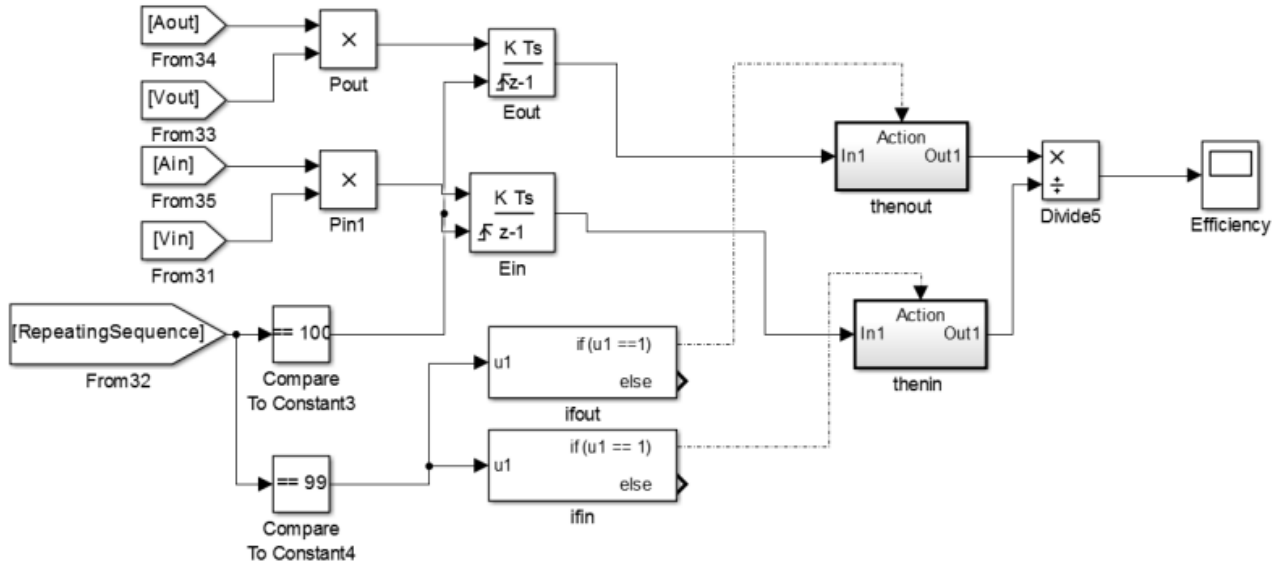

Fig. 7. Efficiency evaluation scheme

As it can be seen on the scheme, the instantaneous input and output power values are integrated during almost whole switching period i.e. the input and output energy values per actual period are calculated, during the penultimate percent of the period the values of the energies are transmitted to data storage and afterwards the integrators' values are zeroed within the last percent of a period. The stored energy values are divided and displayed in a scope as a efficiency value.

6. Simulation

In order to prove higher efficiency of synchronous rectifier comparing to mixed type rectifier a simulation in Matlab Simulink has been carried out. The results of simulation can be observed on the Figure 6.

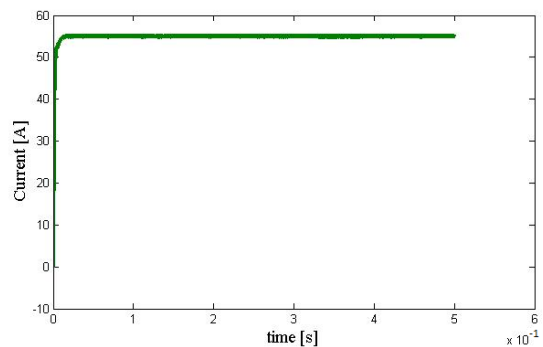

Fig. 9. Modeled mixed type rectifier output current

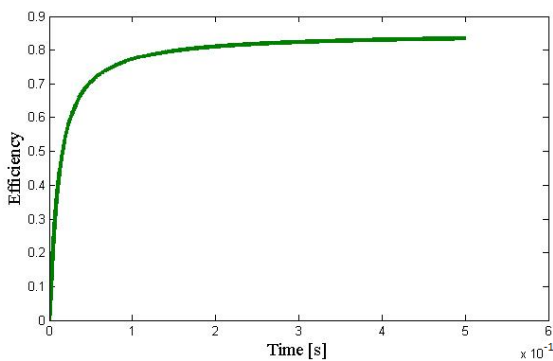

Fig. 8. Modeled mixed type rectifier efficiency

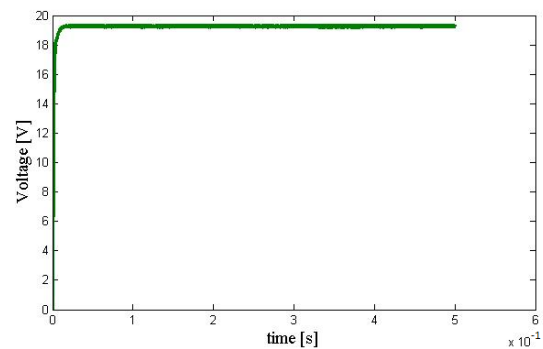

Fig. 10. Modeled mixed type rectifier output voltage

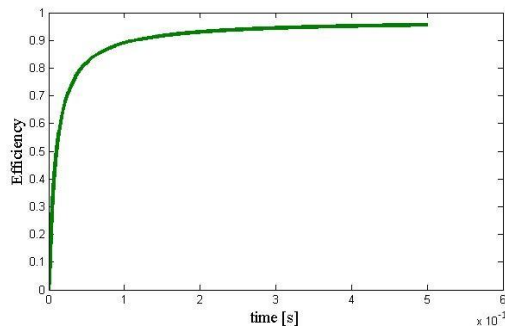

Fig. 11. Modeled synchronous rectifier efficiency

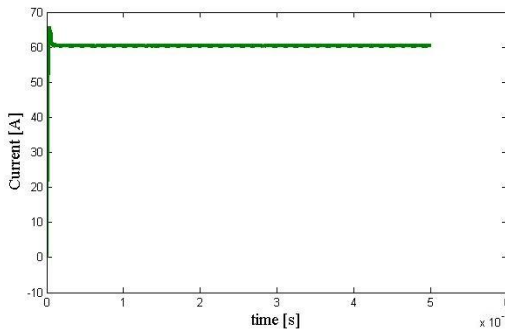

Fig. 12. Modeled synchronous rectifier output current

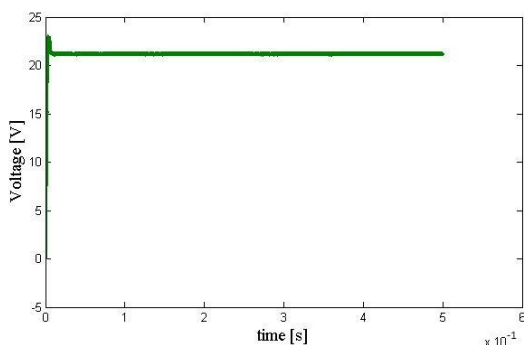

Fig. 13. Modeled synchronous rectifier voltage

Table 3. The simulation results

Parameter No.	Parameter	Parameter symbol	Unit	MTR*	SR**
1	Efficiency	η		0,82	0,95
2	Output voltage	Uout	V	19	21
3	Output current	Iout	A	55	60
4	Output power	Pout	W	1045	1260

*MTR - Mixed-type rectifier

**SR - Synchronous rectifier

As can be seen from the content of the Table 3, the losses of the Mixed type rectifier are higher, that fact is caused by constant voltage drop of diodes used for this method.

7. Conclusion

The review of fast charger concept was conducted, energy efficient techniques were reviewed as well, standardization requirements for fast charger were presented. The conclusion on infeasibility of old types of rectifier as per CHAdeMo standards has been made. Models of two various types of soft switched rectifier have been carried out. Both of them maintain high power density, hence are feasible for use as a fast charger, but the model implementing synchronous rectification presented significantly better efficiency and current value together with approximately the same voltage magnitude. Owing to the said conclusions it can be summarized that synchronous rectifier is a better solution for use as a fast charger in terms of efficiency and charging rate, although it is more complicated and expensive due to necessity of implementing sophisticated control techniques and more complicated electronic schematics.

References

- [1] Badea G.-A.: Supercapacitors – the batteries of the future, Bulletin Scientifique en Langues Étrangères Appliquées 3/2015.
- [2] Braham Ferreira, Wim van der Merwe: Electronic and Electromechanic Power Conversion, IEEE PRESS, John Wiley & Sons inc., Hoboken, New Jersey, 2014.
- [3] Citko T.: Energoelektronika, Układy wysokiej częstotliwości. Wydawnictwo Politechniki Białostockiej, Białystok 2007.
- [4] Kane M.: <http://insideevs.com/chademo-officially-recognized-international-charging-standard-iec/> (available 30.04.2016).
- [5] Tao Sun, Zhigang Liu, Chao Li, Lei Wang, LijunDiao: Design of a 6 kW Battery Charger Based on Full-Bridge Phase-Shifted ZVZCS PWM Converter. Proceedings of the 2013 International Conference on Electrical and Information Technologies for Rail Transportation (EITRT2013), vol. 2, 2013, 51–64.
- [6] Zhe Sun, Eng B.: Full Bridge DC/DC Converter with Zero Current Switching Synchronous Rectification for Auxiliary Power Units. McMaster University, Hamilton, Ontario 2014.
- [7] Terra 51 Fast Charging station: ABB inc. electric vehicle charging infrastructure, New Berlin, WI, 53151, USA
- [8] <http://electrical-riddles.com/topic.php?lang=en&cat=28&topic=882> - accessible on May 7, 2016
- [9] <http://www.chademo.com/wp/technology/safety/> (available 08.05.2016)
- [10] <http://www.chademo.com/wp/technology/userfriendly/> (available 08.05.2016)
- [11] <http://www.chademo.com/wp/technology/future/> (available 08.05.2016)
- [12] <http://www.chademo.com/wp/technology/can/> (available 08.05.2016)
- [13] <http://www.chademo.com/wp/technology/optimal/> (available 08.05.2016)
- [14] <http://www.chademo.com/wp/technology/compatibility/> (available 08.05.2016)

Ph.D. Dariusz Zieliński

e-mail: d.zielinski@pollub.pl



Dariusz Zielinski gained his Ph. D. degree in electrical engineering, specializing in synchronization of power electronic converters in the Faculty of Electrical Engineering and Computer Science at the Lublin University of Technology (2017). Currently he works at the Department of Electrical Machines and Drives of that university. He deals with issues of power electronic, equipment design used primarily in electric power grid and real-time systems.

M.Sc. Mikhail Tokovarov

e-mail: m.tokovarov@pollub.pl



Mikhail Tokovarov is a Ph.D. student at Lublin University of Technology. He is interested in microelectronics and IT. The subject of his master's thesis was "Design and Simulation of a Synchronous Rectifier with implementation of soft-switching technique".