

<http://doi.org/10.35784/iapgos.2833>

## CONTROLLING A FOUR-WIRE THREE-LEVEL AC/DC CONVERTER WITH INDEPENDENT POWER CONTROL IN EVERY PHASE

**Bartłomiej Stefańczyk**

Lublin University of Technology, Faculty of Electrical Engineering and Computer Science, Department of Electrical Drives and Machines, Lublin, Poland

**Abstract.** The article presents the design of a four-wire, three-level AC/DC converter. The converter was controlled with the use of a proportional-resonant controllers based voltage oriented control (VOC). The implemented topology of the AC/DC converter allows to control each of the phases separately. This translates into the possibility of independent control of active and reactive power in each of the phases. In addition, the DC bus of the AC/DC converter is connected in parallel with the energy storage via an isolated DC/DC converter and with a renewable energy sources. The tests were carried out with the use of the designed converter, DSP controller and Matlab/SIMULINK platform, which was used for automatic code generation. The results obtained show that independent control of each of the phases is possible, however, the operation with large power unbalances on each of the phases leads to large current pulsation on the DC bus. This is a phenomenon that threatens the correct operation of the energy storage. As a result, the level of asymmetry between phases should be limited to the level acceptable by the energy storage.

**Keywords:** three-level four-wire converter, control of a 4-wire converter, independent power control in each phase, energy storage

### STEROWANIE CZTEROPRZEWODOWYM TRÓJPOZIOMOWYM PRZEKSZTAŁTNIKIEM AC/DC Z NIEZALEŻNĄ KONTROLĄ MOCY W KAŻDEJ Z FAZ

**Streszczenie.** W artykule przedstawiono projekt czteroprzewodowego trójpoziomowego przekształtnika AC/DC. Sterowanie przekształtnika zrealizowano z wykorzystaniem regulatorów proporcjonalno-rezonansowych opartych na sterowaniu zorientowanym napięciowo (VOC). Zaimplementowana topologia przekształtnika AC/DC pozwala na sterowanie każdą z faz z osobna. Przekłada się to możliwość niezależnej kontroli mocy czynnej i bierniej w każdej z faz. Ponadto szyna DC przekształtnika AC/DC połączona jest równolegle z magazynem energii poprzez izolowaną przetwornicę DC/DC oraz odnawialne źródło energii. Badania przeprowadzono z wykorzystaniem zaprojektowanego przekształtnika, sterownika DSP oraz platformy Matlab/SIMULINK, którą wykorzystano do automatycznej generacji kodu. Otrzymane wyniki wskazują, że sterowanie niezależne każdą z faz jest możliwe jednakże, praca z dużymi asymetriami mocy na każdej z faz prowadzi do dużej pulsacji prądu na szynie DC. Jest to zjawisko zagrażające poprawności działania magazynu energii. W skutek tego poziom asymetrii między fazami powinien być ograniczony do poziomu akceptowalnego przez magazyn energii.

**Słowa kluczowe:** przekształtnik trójpoziomowy czteroprzewodowy, sterowanie przekształtnikiem 4-przewodowym, niezależna kontrola mocy w każdej z faz, magazynowanie energii

### Introduction

Due to the rapidly developing renewable energy sources (RES) industry, more and more generation sources are connected to the power grid by the three-phase inverters, but also single-phase inverters, the operation of which delivers energy only into one of the three phases [2–6, 11, 14]. Adding to this the fact that most household appliances use pulse power supplies, the current consumed by the consumer is asymmetric and non-linear in nature. Another issue is increasing number of loads with simple supply system, which draws the reactive power from the utility grid. The presented phenomena are undesirable and are described in the distribution grid operation and maintenance manual. When  $\text{tg } \phi$  is greater than 0.4, where  $\text{tg } \phi$  is the ratio of reactive power to active power, the operator imposes a penalty on the consumer. In a case, where the consumer has a generation source installed and connected to the power grid, e.g. a photovoltaic installation, he becomes a prosumer, a recipient who can also deliver energy into the grid. In this way, thanks to the use of a four-wire AC/DC converter with independent power control in each of the phases, it can affect the quality of power in the grid, i.e. reduce the THD of the current drawn from and delivered to the grid. For this purpose, there is a need to develop a control algorithm that will ensure the limitation of the THD of the current delivered by the converter with the connected electronic devices consuming the current in a non-linear manner. Additionally, the algorithm should be able to compensate the power reactive power independently in each of the phases. It is also recommended that the converter corrects the symmetry of the phase voltages in order to maintain the correct symmetry of the power grid. For the presented reasons, the aim of the article is to develop a converter control algorithm and to select a topology that will be able to meet the desired requirements.

The algorithm described in the paper is based on proportional-resonant regulators and band-pass filters [7, 13]. Their task is to selectively eliminate higher harmonics with independent power

control in each of the phases. The actual tests were carried out with the use of a four-wire, three-level converter and a Texas Instruments TMS28379D DSP microcontroller. The algorithm was implemented with the use of automatic code generation via the Matlab / SIMULINK platform. The tests were conducted with the mapping of the power grid characterized by strong asymmetry in the load of individual phases.

### 1. Four-wire, three-level AC/DC converter with a proportional – resonance algorithm

The system in which a four-wire three-level AC/DC converter can function is shown in figure 1. This figure shows the configuration of an AC/DC converter with a connected chain of PV panels indirectly controlled by the MPPT algorithm [2, 3]. The connection of both systems was made by means of a non-isolated DC/DC converter. An electrochemical energy storage was connected in parallel to the DC bus of the converter, through an isolated bidirectional DC/DC converter [1, 8, 10, 12], which is designed not only to charge and unload the storage, but also to provide galvanic separation between the storage and the converter and to guarantee a constant voltage on the DC bus independently from the voltage on the chain of PV panels. On the AC side of the converter, a single-phase voltage control scheme is illustrated. Such a simplification was performed for the sake of clarity of the drawing. In order to build a three-phase control system with the properties described in the first part, the algorithm (the area marked with a red frame in the figure 1) should be duplicated three times for each of the phases. Figure 2 shows the topology of the designed AC/DC converter. The control is based on proportional-resonant regulators responsible for the 1, 3, 5, 7, 9 harmonic in turn. Additionally, a PI controller was connected in parallel, thanks to which the possibility of a constant component is eliminated.



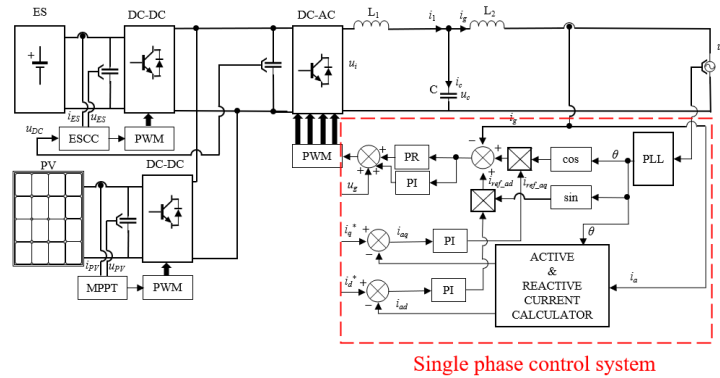

Fig. 1. Simplified algorithm of proportional – resonance converter control for one phase

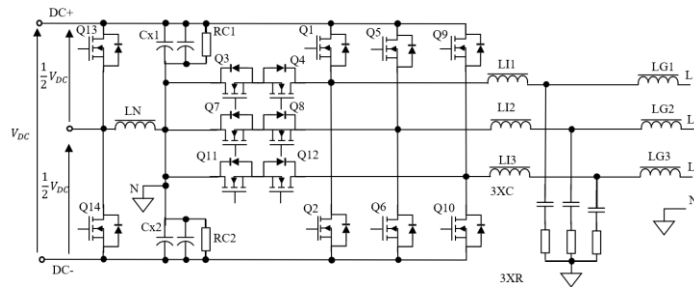

Fig. 2. Diagram of TNPC topology of the DC/AC converter

The parameters of the AC/DC converter are presented table 1.

Table 1. Technical parameters of the four-wire three-level converter AC/DC

Parameter	Value
System output power [kW]	10
DC bus voltage of the AC/DC converter [V]	750
Idle voltage of photovoltaic panels [V]	400
Rated energy storage voltage [V]	48
Capacity of DC bus [mF]	10
Cut-off frequency of the output LCL filter [kHz]	2.8
LCL filter parameters [mH uF mH]	1.2+5+0.38
THDi (at load above 50%) [%]	<3

The energy storage was connected to the converter via a DC/DC converter. The operating range of the converter enforces a bidirectional topology. An algorithm based on Phase-Shift Control (PSC) [1, 9] was used for control. By using such a control method and the topology of the DC/DC converter, the stability of the voltage on the DC bus of the AC/DC converter can be ensured. This is done by taking the excess energy generated by the photovoltaic panels and not converted by the AC/DC converter, or providing energy when the energy generated by the solar panels is insufficient to meet the energy requirements of the AC/DC converter. The task of the modeled AC/DC converter is to provide high-quality energy. The three-level topology of the AC/DC converter allows to reduce the size of the output filter, which eliminates the interference caused by transistor switching noise. Correct connection of the AC/DC converter to the power grid requires reliable synchronization. For this purpose, the Decoupled Double Synchronous Reference Frame Phase Locked Loop (DDSRF-PLL) [15, 17] algorithm was used. The proposed control method is based on feedback, so that even strong interferences present in the network do not threaten the generation of a high-quality synchronization signal [1]. The synchronization signal has a sawtooth shape and is in the range of  $\langle 0, 2\pi \rangle$ . The signal is then converted into a sinusoidal signal with an amplitude of 1. The difference between the setpoint and the feedback is sent to a proportional-resonant controller which consists of a plurality of interconnected resonant proportional controllers [3, 7]. The resonant frequency of the regulator is equal

to the base frequency of the power grid. As a result, the controller only amplifies the fundamental harmonic signal. Regulators connected in parallel are responsible for 3, 5, 7, 9 harmonics in turn. The transfer function describing the control algorithm as well as the amplitude-phase characteristic, taking into account the LCL output filter of the converter is presented in eq. 1.

$$G_i = \left( K_{pl\_1H} + \sum_{n=1,3,5,7,9}^N \frac{K_{il\_nH} 2\omega_{rcl\_nH} s}{s^2 + 2\omega_{rcl\_nH} s + \omega_0^2} \right) \left( \frac{G_d}{K_{vdc\_fdbk}} \right) G_{LCL} G_n \quad (1)$$

where:  $G_i$  – transfer function system,  $K_{pl\_1H}$  – PI regulator gain,  $n$  – the harmonic order,  $\omega_{rcl\_nH}$  – the cut-off frequency,  $K_{il\_nH}$  – individual resonant gain for the n-th harmonic,  $\omega_0$  – base frequency of the filter,  $K_{vdc\_fdbk}$  – gain due to voltage on the DC bus,  $G_d$  – gain of power converter,  $G_{LCL}$  – transfer function LCL filter,  $G_n$  – transfer function notch filter.

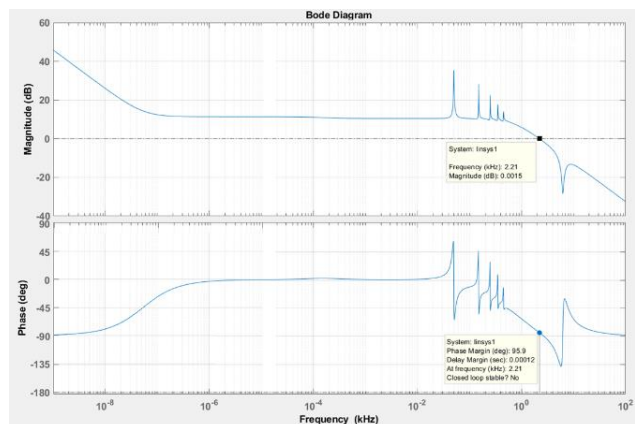

Fig. 3. Amplitude-phase characteristic of the control algorithm

The figure 3 shows the characteristics of the control system. For the most part of the characteristic, the system has a gain of 1. The situation changes when the frequency reaches values equal to the base frequency and the third, fifth, seventh and ninth harmonics, respectively. For the frequencies above the harmonics, the circuit behaves as a low-pass filter. Additionally, a notch filter [17] was used to eliminate the resonant frequency of the LCL

filter. The structure of the proportional-resonant filter is based on a filter with an infinite impulse response (IIR). The settings of the regulators are selected in such a way that the regulator obtains the maximum harmonic amplification for a given frequency while maintaining the appropriate phase reserve. When selecting the controller settings, a compromise should be made between the maximum gain and the error resulting from frequency deviations in the power grid. The block named "Active & Reactive block calculator" uses the power calculation method based on the Orthogonal Signal Generator (OSG) [16]. The active power  $P$  and reactive power  $Q$  for a single-phase application can be calculated with the help of OSG systems. Formulas describing the method used (2), (3). The subscripts "g $\alpha$ " and "g $\beta$ " denote the "alpha" and "beta" components of the grid voltage/current in a  $\alpha\beta$ -stationary reference frame. The subscripts "g $\alpha$ " and "g $\beta$ " denote the "alpha" and "beta" components of the grid voltage/current in a  $\alpha\beta$ -stationary reference frame. Figure 4 shows the structure of the power calculation method.

$$P = \frac{1}{2}(v_{g\alpha}i_{g\alpha} + v_{g\beta}i_{g\beta}) \quad (2)$$

$$Q = \frac{1}{2}(v_{g\beta}i_{g\alpha} - v_{g\alpha}i_{g\beta}) \quad (3)$$

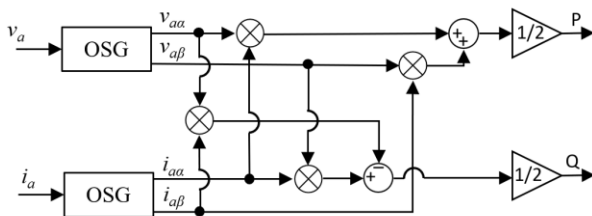

Fig. 4. System for measuring active and reactive power based on orthogonal signal generator for single phase systems

The construction of the OSG system is based on the use of a delay unit which introduces a phase shift of 90° corresponding to the fundamental component of the input signal. The OSG system based on the SOGI filter is used in this implementation because it is an adaptive filtering system and behaves as a generalized integrator. The use of the OSG system allowed for a lower computational load thanks to the quick and accurate response.

Due to the described properties, the proposed control method enables the delivery and drawing of energy from the grid with the use of a converter. The used control system ensures very good dynamics, which translates into a very low THDi at the level of 1–2% at the converter load above 50% of the rated load.

## 2. Laboratory research

The laboratory stand on which the tests were carried out consists of five parts:

- four-wire, three-level power module made in TNPC topology,
- LCL filter with EMC filter,
- energy storage emulator in the form of a bidirectional ITECH IT6012-C power supply,
- three isolation transformers,
- a controller based on the TI TMS320F28379D microcontroller with Hall sensors for voltage and current measurement.

The constructed stand is illustrated in figure 5.

The obtained test results are shown in the oscillograms in figure 6.

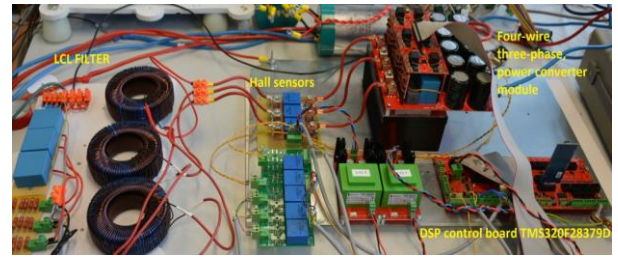

Fig. 5. Laboratory stand on which the research was carried out

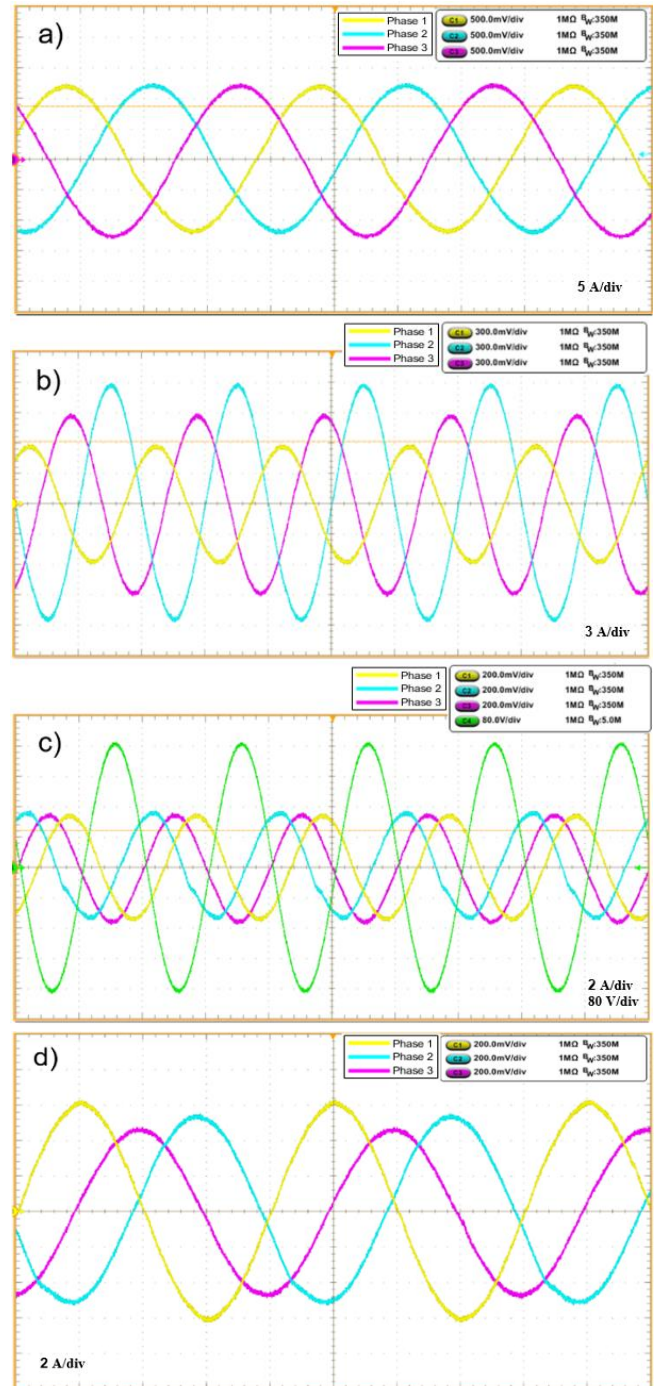

Fig. 6. Oscillograms of the converter operation: a) three-phase currents during inverter operation, symmetrical operation of 2 kW per phase, b) asymmetrical operation of 2 kW per phase, c) three-phase currents and L3 phase voltage, L1 and L2 phase inverter operation, L3 phase rectifier operation, d) three-phase currents, L3 phase only active power, L1 and L2 phases with additional reactive power

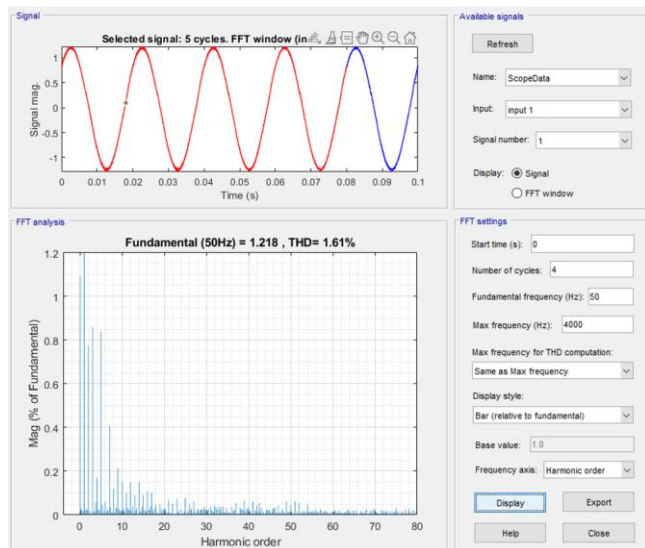

Fig. 7. Analysis of the current output to the network by the converter AC/DC THD current is 1.61%.

The obtained results confirmed the correctness of the applied topology and the selected control method. During tests with high asymmetry, the ITECH 6012-C power supply was used as the DC source. The used power supply has the function of emulating an energy storage. In the case of asymmetric operation, a current with pulsation of 100 Hz, dangerous for the energy storage, was observed, the amplitude of which increased with the increase of induced asymmetry. This problem is being considered and the ways of eliminating the phenomenon will be described in the next article.

### 3. Conclusions/summary

The article discusses the problem with the stability of the low-voltage electrical network caused by the increasing number of renewable energy sources and loads that draw current in a non-linear manner while consuming reactive power. As a result, these devices cause deterioration of grid parameters and voltage asymmetry between phases. In the following part of the paper, an AC/DC four-wire three-level converter with parallel energy storage is proposed as a solution to the problem. The control algorithm was based on proportional-resonant filters specifically targeting odd harmonics. Multiresonant control combined with DDSRF-PLL synchronization allowed for accurate control of active and reactive power produced and consumed by the AC/DC converter. The performed tests confirmed the validity of the assumptions. The article presents four cases of the converter operation. With symmetrical work and load of the converter in 60% THD of the issued current was 1,61% (figure 7). In the further part the asymmetric operation with phase loading in the ratio  $L1 = 50\%$ ,  $L2 = 75\%$ ,  $L3 = 100\%$  was shown. The induction of such asymmetry resulted in current flow in the neutral wire. It was observed that the higher the asymmetry, the higher the current amplitude in the neutral conductor. The next oscillogram shows the extreme case where the phases L1 and L3 are delivering power to the grid, while phase L2 draws power from the grid. In this case, the current in the neutral wire is equal to twice the phase current. Such a large current in the neutral conductor results in a large current pulsation on the DC bus of the converter. Its frequency is 100 Hz. The current with such parameters is a threat to the correct operation of the energy storage. Therefore, a power supply with the ability to emulate the energy storage was used in the study. After the tests it was found that such a large current in the neutral line is not a problem for power electronics components. Only a small temperature spike on the DC bus capacitors was reported. The last oscillogram shows the operation of the converter in the mode delivering and drawing reactive

power. The converter, thanks to its characteristics, can successfully work as a reactive power compensator. In conclusion, based on the literature analysis, the selection of the converter topology and control method proved to be correct. The device in this configuration can successfully guarantee the prosumer adequate parameters of the LV grid. Further research should focus on solving the problem of the DC bus current pulsation at operation with high asymmetry.

### References

- [1] Barlik R., Nowak M., Grzejszczak P.: Power transfer analysis in a single phase dual active bridge. Bulletin of the Polish Academy of Sciences: Technical Sciences 61(4), 2013, 809–828 [http://doi.org/10.2478/bpasts-2013-0088].
- [2] Brito M. A. G. de, Galotto L., Sampaio L. P., Melo G. d. A. e, Canesin C. A.: Evaluation of the Main MPPT Techniques for Photovoltaic Applications. IEEE Transactions on Industrial Electronics 60(3), 2013, 1156–1167.
- [3] Chatterjee A., Mohanty K. B.: Development of stationary frame PR current controller for performance improvement of grid tied PV inverters. 9th International Conference on Industrial and Information Systems (ICIIS), 2014, 1–6 [http://doi.org/10.1109/ICIINFS.2014.7036586].
- [4] Govind D., Suryawanshi H. M., Nachankar P., Narayana C. L.: Performance Comparison of Standalone AC Microgrid with Inner Loop Proportional Integral and Proportional Resonant Current Controllers. IEEE First International Conference on Smart Technologies for Power, Energy and Control (STPEC), Nagpur 2020, 1–5 [http://doi.org/10.1109/STPEC49749.2020.9297686].
- [5] Grijalva S., Costley M., Ainsworth N.: Prosumer-based control architecture for the future electricity grid. IEEE International Conference on Control Applications, 2011, 28–30 [http://doi.org/10.1109/CCA.2011.6044467].
- [6] Ikeda S., Kurokawa F.: Isolated Bidirectional Boost Full Bridge DC-DC Converter for Energy Storage System, 2018 20th European Conference on Power Electronics and Applications, 2018, P.1–P.8.
- [7] Islam S., Zeb K., Din, W., Khan I.: Design of a Proportional Resonant Controller with Resonant Harmonic Compensator and Fault Ride Through Strategies for a Grid-Connected Photovoltaic System. Electronics 7, 2018, 451.
- [8] Jarzyna W., Zieliński D., Gopakumar K.: An evaluation of the accuracy of inverter sync angle during the grid's disturbances. Metrology and Measurement Systems 27(2), 2020, 355–371 [http://doi.org/10.24425/mms.2020.132780].
- [9] Kumar B. M., Kumar A., Bhat A. H., Agarwal P.: Comparative study of dual active bridge isolated DC to DC converter with single phase shift and dual phase shift control techniques. Recent Developments in Control, Automation & Power Engineering, 2017, 453–458 [http://doi.org/10.1109/RDCAPE.2017.8358314].
- [10] Lee J., Jeong Y. and Han B.: A Two-Stage Isolated/Bidirectional DC/DC Converter With Current Ripple Reduction Technique. IEEE Transactions on Industrial Electronics 59(1), 2012, 644–646.
- [11] Patil S. N., Prasad R. C.: Design and development of MPPT algorithm for high efficient DC-DC converter for solar energy system connected to grid. International Conference on Energy Systems and Applications, 2015, 228–233.
- [12] Penghui Jing, Cong Wang, Wei Jiang, Guopeng Zhang.: Performance analysis of isolated three-level half-bridge bidirectional DC/DC converter. Proceedings of 7th International Power Electronics and Motion Control Conference, 2012, 1527–1531 [http://doi.org/10.1109/IPEMC.2012.6259058].
- [13] Praneeth A. V. J. S., Azeez N. A., Patnaik L., Williamson S. S.: Proportional resonant controllers in on-board battery chargers for electric transportation. IEEE International Conference on Industrial Electronics for Sustainable Energy Systems, 2018, 237–242 [http://doi.org/10.1109/IESES.2018.8349880].
- [14] Przytuła K., Zieliński D.: Influence of power converters on increasing the share of renewable energy sources. Acta Energetica 1(26), 2016, 125–131 [http://doi.org/10.12736/issn.2300-3022.2016111].
- [15] Wu X., Huang T., Chen X., Hu H., He G.: Frequency Characteristic and Impedance Analysis on Three-Phase Grid-Connected Inverters Based on DDSRF-PLL. 10th International Conference on Power Electronics and ECCE Asia, 2019, 1053–1058.
- [16] Yang Y., Blaabjerg, F.: A new power calculation method for single-phase grid-connected systems. 2013 IEEE International Symposium on Industrial Electronics, 2013, 1–6 [http://doi.org/10.1109/ISIE.2013.6563684].
- [17] Zieliński D., Lipnicki P., Jarzyna W.: Synchronization of voltage frequency convert-ers with the grid in the presence of notching. International Journal for Computation and Mathematics in Electrical and Electronic Engineering – COMPEL 34(3), 2015, 657–673 [http://doi.org/10.24425/mms.2020.132780].

M.Sc. Eng. Bartłomiej Stefańczak  
e-mail: b.stefanczak@pollub.pl

Graduated from the Faculty of Electrical Engineering and Computer Science of the Lublin University of Technology in 2019. Since then also employed as assistant lecturer at the university's Department of Electrical Drives and Machines. His research focuses on AC/DC power converters with energy storage. He is a member of the team working on National Centre for Research and Development projects.



<http://orcid.org/0000-0001-7071-9131>

otrzymano/received: 28.11.2021

przyjęto do druku/accepted: 15.12.2021