

NEW METHOD OF ON-LINE SUCCESSIVE-APPROXIMATION ADC CALIBRATION

Serhii M. Zakharchenko¹, Tetiana I. Korobeinikova², Aigul Tungatarova³, Bakhyt Yeraliyeva³

¹Vinnitsia National Technical University, Faculty of Information Technologies and Computer Engineering, Vinnitsia, Ukraine, ²Lviv Polytechnic National University, Institute of Computer Technologies, Automation and Metrology, Lviv, Ukraine, ³M. Kh. Dulaty Taraz Regional University, Taraz, Kazakhstan

Abstract. A new method of successive approximation ADC calibration without interruption of the main conversion process is proposed. The method is based on the use of information redundancy in the form of redundant positional number systems. The method is based on the selection and analysis of unused combinations in the redundant ADC conversion characteristic.

Keywords: analog-to-digital converter (ADC), successive-approximation algorithm, self-calibration, redundant number systems, ADC transfer function

NOWA METODA KALIBRACJI ON-LINE PRZETWORNIKA AC METODĄ KOLEJNYCH APROKSYMACJI

Streszczenie. Zaproponowano nową metodę kalibracji przetwornika AC z aproksymacją sukcesywną bez przerywania głównego procesu konwersji. Metoda opiera się na wykorzystaniu redundancji informacji w postaci redundantnych systemów liczb pozycyjnych. Metoda opiera się na selekcji i analizie niewykorzystanych kombinacji w charakterystyce redundantnej konwersji AC.

Słowa kluczowe: przetwornik analogowo-cyfrowy (AC), algorytm kolejnych aproksymacji, samokalibracja, redundantny system liczbowy, funkcja przetwarzania przetwornika AC

Introduction

Successive approximation ADCs have found wide application in information-measuring, data collection and processing, voice and video processing systems. However, when the resolution of the ADC is more than 12 bits, the problem of ensuring the conversion accuracy appears. This is the result of ADC bits deviations under the influence of environmental factors (temperature, humidity, pressure). The ways to overcome this problem can be divided into technological and algorithmic. The technological methods are cost- and time-consuming, and provide the ability to improve the linearity by several bits. A more universal method of overcoming this problem is to use the procedure of ADC bits calibration [4, 5, 9]. The calibration procedure is performed after turning on the device and periodically is repeated during operation, and the ADC can operate either in the main conversion or calibration mode. The use of weight redundancy in the successive approximation ADC permits to make the calibration procedure exclusively in digital form without physical or electrical impact on the ADC digits [1]. Weight redundancy may be used for compensation the dynamic errors in the process of analog-to-digital conversion [6, 7]. However, the problem of on-line correction (without interrupting the main conversion process) of the ADC bits remains actual. One of the possible solutions is using split architecture [14], but it involves using of several identical ADCs. The work [13] shows the possibility of cyclic ADC on-line calibrating by analysing the transfer function. The principal opportunity of on-line calibration redundant ADC was proved in [12]. The single bit deviations determining process for redundant ADC was considered in [11].

1. Successive approximation ADC transfer function analysis

The successive approximation algorithm provides the sequential determination of the output code bits from most significant bit (MSB) to least significant (LSB). The results of the algorithm operation for any input signal are demonstrated by the ADC transfer function (TF). The mathematic representation of ADC TF shows the expression (1) [2, 3, 10]

$$A(K^s) = \sum_{i=0}^{n-1} a_i \cdot Q_i, \quad (1)$$

where K – code combination, s – the number of code combination (decimal notation of binary combination), n – ADC resolution,

$Q_i = \alpha^i(1 + \delta_i)$ – bit value with number i , where α – radix, δ_i – i -bit deviation, $a_i \in \{0,1\}$ – bit values of K .

The graphical interpretation of (1) for $n=5$ and different radix is shown in Fig. 1

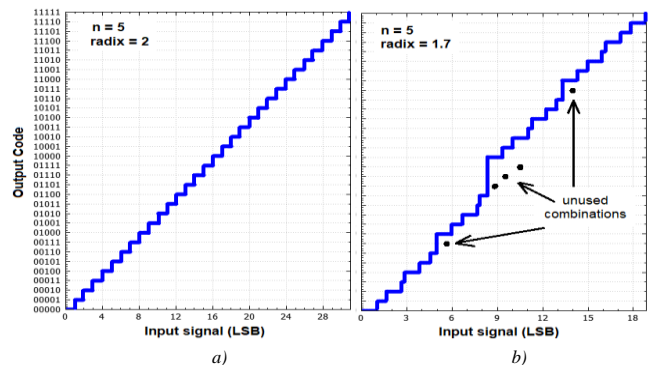

Fig. 1. Transfer function of n -bit successive approximation ADC for a) radix equal 2; b) radix equal 1.7

When using the binary number system, the TF has the form of a regular staircase (Fig. 1a), and all possible code combinations are used to form the output code. When using a number system with a radix less than 2, some code combinations fall out of the TF. For example, in Fig. 2 these are five combinations: 00111, from 01101 to 01111 and 10111. In [9] it is proposed to call them “unused” (UnC). Other combinations will be calling “used” (UC). The expression (2) determines if the combination belongs to unused category or not [8, 10]:

$$A(K_{UC}^{m-1}) < A(K_{UC}^l) \leq A(K_{UC}^m), \quad (2)$$

where the input analog signal values correspond to the UC with the numbers $m-1$ and l , while the UnC with the number m and $l > m$.

In [11] it is shown that UnC form certain groups, called “unused combinations zones” (UnC zone). Each UnC zone has its own boundaries (from K_{UC}^m to K_{UC}^{l-1}) and is located in a certain place of the TF. In the central part of the TF there is a zone of the $(n-1)$ -th level (in figure 1 these are three combinations from 01101 to 01111), in the same figure there is a zone of the $(n-2)$ -th level, consisting of two subzones. The first subzone, which is located in the lower half of the TF, includes the combination 00111, the second subzone contains the combination 10111. The quantity of UnC in certain zone or subzone may be calculated as $l-m$.

The relationship between the number of UnC zone N_z , ADC radix and ADC resolution n is shown in Tab. 1

Table 1. The relationship between the number of UnC zone N_z , ADC radix resolution

α	1.618÷1.839	1.840÷1.928	1.929÷1.966	1.967÷1.984
N_z	n-3	n-4	n-5	n-6

2. The influence of ADC bit's deviations on TF

K_{UC}^l in (2) is a top border combination of certain zone (subzone). It's value is fixed and it is independent of ADC radix. For $(n-1)$ -th level zone K_{UC}^l value equal 100...0 (10000 combination on Fig. 1b), for $(n-2)$ -th level zone – 0100...0 (first subzone, 01000 combination on Fig. 1b) and 1100...0 (second subzone, 11000 combination on Fig. 1b). Therefore the location of the border combination on TF is defined only most significant bits (MSB) values. On the other hand the location of UnC is depends on least significant bits values (combinations 01111, 01110 and 01101 on Fig. 2b). If the MSB's value will be changed, the mutual location of border combinations and UnC will be changed too. As a result some UnC may transfer to used category and vice versa. The influence of -10% and +10% MSB deviation on TF is shown on Fig. 2.

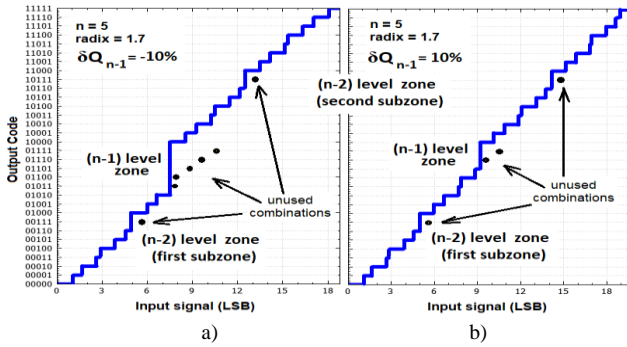

Fig. 2. Transfer function of 5-bit successive approximation ADC for radix equal 1.7 with MSB deviation a) -10%; b) +10%

Fig. 2 demonstrates, that MSB deviation affects only on UnC quantity in $(n-1)$ th level zone, but has not effect on other level zones.

The relationship between MSB deviation and the UnC quantity may be calculated after substitution (1) to (2):

$$\frac{\sum_{i=0}^{n-2} a_i \alpha^i}{\alpha^{n-1}} - 1 < \delta_{n-1}^{p_{n-1}} \leq \frac{\sum_{i=0}^{n-2} b_i \alpha^i}{\alpha^{n-1}} - 1, \quad (3)$$

where a_i and b_i are code combinations bits of K_{UC}^{m-1} and K_{UC}^m , p_{n-1} is the UnC quantity in the $(n-1)$ -level zone.

The generalized rule of relationship between k -bit deviation and UnC quantity in the j -level zone will be:

If $j < k$: the k -bit deviation does not influence on UnC quantity in the j -level zone;

$$\text{If } j = k: \frac{\sum_{i=0}^{j-1} a_i \alpha^i}{\alpha^k} - 1 < \delta_k^{p_j} \leq \frac{\sum_{i=0}^{j-1} b_i \alpha^i}{\alpha^k} - 1, \quad (4)$$

$$\text{If } j > k: \frac{\alpha^j - \sum_{i=0}^{j-1} a_i \alpha^i}{\alpha^k} > \delta_k^{p_j} \geq \frac{\alpha^j - \sum_{i=0}^{j-1} b_i \alpha^i}{\alpha^k}. \quad (5)$$

Since different bit deviations have influence on different UnC zones, it is important to estimate the sensitiveness of the certain zone to different bit deviations.

Equation (6) demonstrates the ratio of $\delta_{n-1}^{p_{n-1}}$ influence to $\delta_{n-2}^{p_{n-1}}$:

$$\frac{\delta_{n-1}^{p_{n-1}}}{\delta_{n-2}^{p_{n-1}}} = \frac{\sum_{i=0}^{n-2} a_i \alpha^i}{\alpha^{n-1}} - 1 \bigg/ \frac{\alpha^{n-1} - \sum_{i=0}^{n-2} a_i \alpha^i}{\alpha^{n-2}} = -\frac{1}{\alpha} \quad (6)$$

So the largest influence on j -level UnC zone has the j -bit deviation. The $(j-1)$ -bit deviation has $-\alpha$ times less influence. Since “-“ indicates the different change direction: positive j -bit deviation results in reducing the UnC number in j -level zone, but results in increasing the UnC number in $(j+1)$ -level zone.

3. The bit's weights calculation algorithm

In the case of simultaneous different bit's deviations the step by step calculation algorithm may be used.

Step 1. Define the number of least UnC level zone with UnC quantity change and assign it to variable j .

Step 2. Calculate the minimum and maximum values of j -bit deviations:

$$\delta_{j \min}^{p_j} = \frac{\sum_{i=0}^{j-1} a_i Q_i}{\alpha^j} - 1, \quad (7)$$

$$\delta_{j \max}^{p_j} = \frac{\sum_{i=0}^{j-1} b_i Q_i}{\alpha^j} - 1. \quad (8)$$

Step 3. Calculate the mean value of the of the j -bit deviation:

$$\delta_j^{p_j} = \frac{\delta_{j \min}^{p_j} + \delta_{j \max}^{p_j}}{2} \quad (9)$$

Step 4. Calculate the correct value of the j -bit:

$$Q_j = \alpha^j (1 + \delta_j^{p_j}) \quad (10)$$

Step 5. Recalculate $j = j+1$, if $j < n$ go to Step2, $j = n$ – calculation finished.

The results of algorithm realization for 6-bit ADC illustrated in Tab. 2

Table 2. The results of algorithm realization for 6-bit ADC

Bit number	0	1	2	3	4	5
Bit weight (LSB)	1	1.7	2.89	4.91	8.35	14.20
Bit weight real deviation (%)	0	0	0	5	-10	5
Bit weight estimated deviation (%)	0	0	0	3.6	-12.7	2.7
Estimation error (LSB)	0	0	0	-0.07	-0.22	-0.33

4. Method realization

For method realization the redundant successive approximation ADC structure [4] has been modified, so the new unit has been added (Fig. 3).

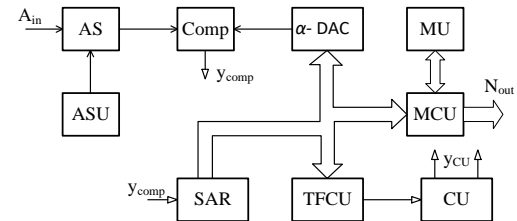

Fig. 3. Redundant successive approximation ADC with transfer function control unit

The main ADC units: AS – analog switch for input or auxiliary signal commutation on comparator input; ASU – auxiliary signal unit generates auxiliary signal for initial calibration; α -DAC – redundant DAC; MU, CU and MCU – memory unit, control unit and main computing unit are used for

algorithm realization. The transfer function control unit (TFCU) is a new block that used for unused combinations identification.

Simplified algorithm of redundant successive approximation ADC functioning with transfer function control illustrates on Fig. 4.

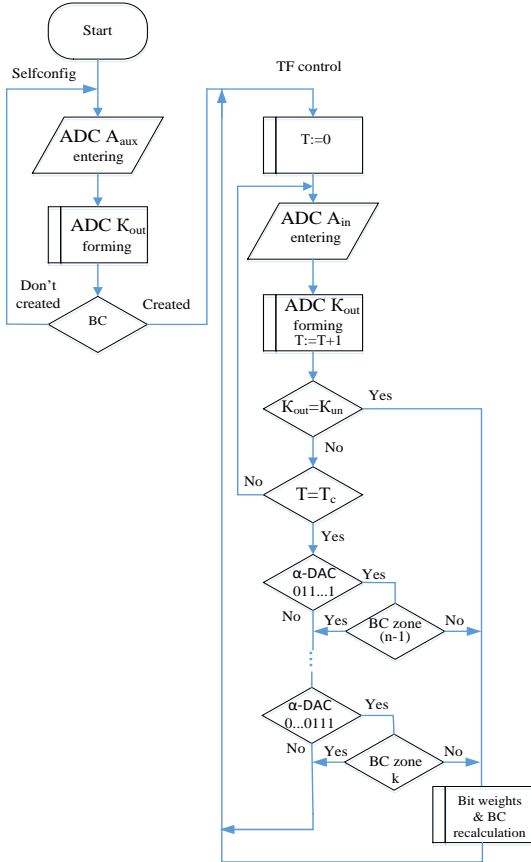

Fig.4. Redundant successive approximation ADC with transfer function control algorithm

Algorithm consists of two parts: self-configuration (Selfconfig) and main ADC conversion with transfer function control (TF control). Self-configuration is the first step after ADC turns on. The ASU generates linearly increasing signal which is converted by ADC. The aim of this phase is a border combination (BC) finding. The border combination is a last used combination before cortege of unused combinations (bottom BC), or first used combination after cortege of unused combinations (top BC). When all BCs pares are created the main ADC conversion phase with TF control begins.

During this phase the input signal converted to digital code TFCU instantly controls the transition of unused combinations in used category and vice versa. UnC to UC transition control is very simple because all BC pairs are created during Selfconfig phase. Every α -DAC code is checked if it belongs to unused combination zones ($K_{out} = K_{un}$). In the case of positive result the bit's weights calculation algorithm starts and new bit weights are calculated. BCs are renewed too.

The UC to UnC transition control is more complicated because it foresees the control of non-appearance of UC, when it must appear. The first applicants on UC to UnC transition are bottom border combinations. On the other side it is necessary the appearance of corresponding value of A_{in} on the ADC input. To control the transition of bottom border combinations to unused category, TFCU identifies the situations when top BC has appeared, but bottom BC has not appeared during control time interval T_c . It may be possible because

$$A(K_{IBC}) - A(K_{BBC}) \leq 1LSB, \quad (11)$$

where K_{IBC} and K_{BBC} are top and bottom border combinations for the same UnC zone.

5. Transfer function control unit realization

Transfer function control unit is a main specific unit on the Fig. 3. It must:

- 1) Ensure the fixation of the bottom border combination obtained in the process of self-configuration.
- 2) Select only combinations that are included or may be included in the proper zone of unused combinations.
- 3) Organize the comparison of the input combination, which was marked in item 2 with border combination fixed in item 1.
- 4) Ensure the formation of the control signal in case of transition of the unused combination to the category of used and vice versa.

TFCU consist of different subunits. Possible realization of control subunit for traversing UnC zones by the input signal illustrates on Fig. 5.

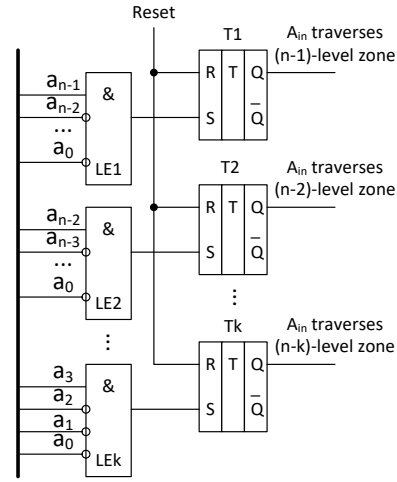

Fig. 5. Control subunit for traversing UnC zones by the input signal

Both: Logical element LE_i and RS-trigger T_i – control the input signal traversing via the UnC (n-i)-level zone. The quantity of $LE-T$ pairs corresponds to the number of UnC zones. It is important that LE_i chooses all top border combinations from all subzones (n-i)-level zone.

Another TFCU subunit illustrates on Fig. 6.

Zone combinations filter is used for selection of combinations which situated or may be situated in the zone of unused combinations of appropriate level (in this sample (n-2)-level of 6-bit ADC). A common feature of all these combinations are fixed values of the (n-2)-nd and (n-3)-rd bits, they are "0" and "1" respectively. This combination allows the commutation of lower bits of these code combinations at the inputs A of the comparator. The other comparator inputs receive the values of least significant bits of actual bottom border combination. In fact "1" on the $A > B$ comparator output indicates that combination transits from UnC category to UC category.

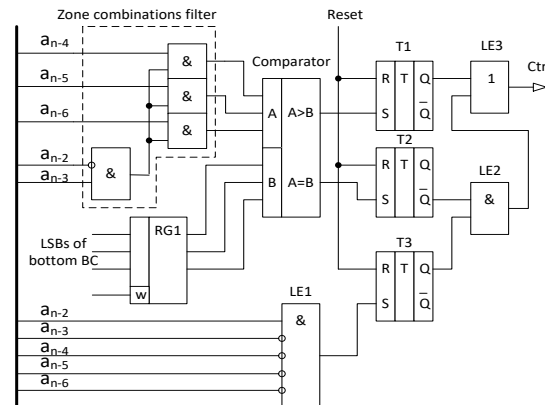

Fig. 6. Zone (n-2)-level control subunit for 6-bit redundant ADC

On the other hand if during some time the top border combination has formed on the SAR out ("1" on the LE1 out) but bottom border combination has not formed ("0" on the A = B comparator's output) it that combination transits from UC category to UnC. In both cases TFCU generates control signal for bit weights recalculation and the values of bottom BCc renewing.

6. Conclusions

It is shown that the use of weight redundancy in the form of redundant positional number systems creates fundamentally new opportunities for self-calibration analog to digital converter, the main feature of which is the execution of the calibration procedure exclusively into the digital form without the use of additional analog measures and components. Moreover the calibration may be performed on-line without interruption the main conversion process.

The structure of the ADC transfer function for successive approximation ADC with weight redundancy is analyzed, as a result the mathematical model of the ADC transfer function is improved by allocating zones of unused combinations.

Mathematical dependences between the different digits weights of ADC deviations and the list of unused combinations in the transfer function that allowed estimating weights digits deviations value without main conversion interruption are established.

A bits deviations estimating method of successive approximation ADC is proposed. It allows determining the deviations of converter individual bits without main conversion process interruption and thus reducing technological waste of time. Redundant successive approximation ADC with transfer function control algorithm is offered.

The practical implementation of bits weights deviations estimating method of the redundant successive approximation ADC by transfer function analysis is proposed. It allows implementing on-line calibration of SAR ADC with weight redundancy by adding the transfer function control unit. The technical realization solutions of transfer function control unit are offered.

References

- [1] Azarov O. et al.: Charge accumulation self-calibrating ADC with redundant number system. *Universum*, Vinnytsia 2005.
- [2] Azarov O. et al.: Method of correcting of the tracking ADC with weight redundancy conversion characteristic. *Proc. SPIE* 9816, 2015, 98161V.
- [3] Azarov O. et al.: Method of glitch reduction in DAC with weight redundancy. *Proc. SPIE* 9816, 2015, 98161T.
- [4] Lee H.S., Hodges D., Gray P.: A Self-calibrating 15-bit CMOS A/D Converter. *IEEE J. Solid-State Circuits* 19(6), 1984, 813–817.
- [5] Lee H.S., Hodges D.: Self-calibration technique for A/D converters. *IEEE Transactions on circuits and systems* 30(3), 1983, 188–190.
- [6] Ogawa T. et al.: SAR ADC Algorithm with Redundancy and Digital Error Correction. *IEICE Trans. Fundamentals* E93-A(2), 2010.
- [7] Ogawa T. et al.: SAR ADC Algorithm with Redundancy. *IEEE Asia Pacific Conference on Circuits and Systems*, Macao, China, 2008, 268–271.
- [8] Osadchuk V. S., Osadchuk A. V.: The magneticreactive effect in transistors for construction transducers of magnetic field. *Electronics and Electrical Engineering. Technologija* 3(109), 2011, 119–122.
- [9] Tan K. S. et al.: Error correction techniques for high-performance differential A/D Converters. *IEEE J. Solid-State Circuits* 25(6), 1990, 1318–1327.
- [10] Wójcik W. et al.: Method of evaluating the level of confidence based on metrological risks for determining the coverage factor in the concept of

uncertainty. *Proceedings of SPIE* 10808, 2018, 108082C [<http://doi.org/10.1117/12.2501576>].

- [11] Zakharchenko S. et al.: Bit error notification and estimation in redundant successive approximation ADC. *Informatyka, Automatyka, Pomiar i Gospodarcze i Ochronie Środowiska* 10(4), 2020, 29–32.
- [12] Zakharchenko S. et al.: The rapid detection method of deviations single digit weights for successive approximation ADC with weight redundancy. *Information Technologies and Computer Engineering* 32(1), 2015, 40–47.
- [13] Zakharchenko S. et al.: The successive approximation ADC linearity operation control method. *Visnyk Lviv Polytechnic National University: Heat energy. Environmental engineering. Automation* 792, 2014, 21–28.
- [14] Zakharchenko S., Troianovska T.: Method of cyclic ADC calibration by the conversion characteristics analysis. *2nd International Conference on Advanced Information and Communication Technologies, AICT 2017*, 120–123.

Ph.D. Serhii Zakharchenko

e-mail: zahar@vntu.net

Serhii Zakharchenko is Associate Professor of the Department of Computer Engineering at the Vinnytsia National Technical University. His main scientific interests include analog to digital conversion, redundant number systems.



<http://orcid.org/0000-0003-3977-2908>

Ph.D. Tetiana Korobeinikova

e-mail: tetianakorobeinikova@gmail.com

Ph.D., Associate Professor of Department of Information Technology Security, Lviv Polytechnic National University. Research Interests: information technologies, computer networks, cybersecurity.



<http://orcid.org/0000-0003-2487-8742>

Ph.D. Aigul Tungatarova

e-mail: tungatarova70@gmail.com

Candidate of Pedagogical Sciences – Department of Information Systems, Taraz Regional University named after M.Kh.Dulaty, Kazakhstan. Research area: information technology, information security.



<http://orcid.org/0000-0001-7600-9608>

M.Sc. Bakhyt Yeraliyeva

e-mail: yeraliyevabakhyt81@gmail.com

Senior lecturer of the Information Systems Department, Faculty of Information Technology, M. Kh. Dulaty Taraz Regional University, Taraz, Kazakhstan.

Research interests: Information technologies, fiber-optic technologies, microprocessor systems.



<http://orcid.org/0000-0002-8680-7694>