

EXPANSION OF THE AREA OF PRACTICAL APPLICATION OF THE PLC CONTROL SYSTEM WITH PARALLEL ARCHITECTURE

Sergiy Tymchuk¹, Oleksiy Piskarev¹, Oleksandr Mirosnyk², Serhii Halko³, Taras Shchur⁴

¹State Biotechnological University, Faculty of Energy, Digital and Computer Technologies, Department of Automation and Computer Integrated Technologies, Kharkiv, Ukraine, ²State Biotechnological University, Faculty of Energy, Digital and Computer Technologies, Department of Electricity Supply and Energy Management, Kharkiv, Ukraine, ³Dmytro Motornyi Tavria State Agrotechnological University, Department of Information Technologies of Design named after V. M. Naidysh, Melitopol, Ukraine, ⁴Lviv National Environmental University, Dubliany, Ukraine

Abstract. The analysis of architecture is carried out and offers concerning expansion of a area of practical application of PLC of parallel action are offered. The proposed methodology for constructing a logical control automaton of parallel action, the developed models, algorithm and structures represent a theoretical platform for the practical implementation of information technology for parallel logical control of railway automation objects.

Keywords: programmable logic controllers, parallel architecture, software control system

ROZSZERZENIE OBSZARU PRAKTYCZNEGO ZASTOSOWANIA SYSTEMU STEROWANIA PLC O ARCHITEKTURĘ RÓWNOLEGLĄ

Streszczenie. Przeprowadzono analizę architektury i zaproponowano rozszerzenie obszaru praktycznego zastosowania PLC o działania równoległym. Zaproponowano metodologię budowy logicznego automatu sterującego o działaniu równoległym, opracowano modele, algorytm i struktury, które stanowią teoretyczną platformę dla praktycznej implementacji technologii informatycznych do równoległego logicznego sterowania obiektami automatyki kolejowej.

Słowa kluczowe: programowalne sterowniki logiczne, architektura równoległa, programowy system sterowania

Introduction

One of the effective directions of scientific and technological progress in the automation of objects is the development and application of the latest information technologies using microprocessor programmable logic controllers (PLC) and modern tools [3].

The practical application of these technologies has revealed not only their unconditional advantages in comparison with those used previously, but also significant drawbacks, the main of which is the sequential principle of processing the flow of commands and data, as a result of which both the speed of logical control of objects and the probability of failures become significantly dependent on both the number of monitored sensors and controlled mechanisms, as well as the length of the control program (the number of processor cycles expended), as a result of which microprocessor PLCs, which have sufficiently high reliability indicators, often do not provide the necessary level of information processing reliability when controlling automation objects and therefore for direct control of actuators are used very limitedly [11].

In recent years, for the reliable and efficient implementation of the functions of logical control of automation objects, the active use of information technologies based on the use of programmable logic integrated circuits (FPGA) has begun, in which the capabilities and advantages of regular microelectronic structures are fully implemented and can be effectively used.

The widespread use of programmable logic controllers (PLCs) in industrial production has had a significant impact on reducing costs and improving the quality of products.

Logic controllers have dozens of inputs/outputs for connecting sensors and actuators, but there are models that support more than a hundred inputs/outputs. Controllers implement the simplest typical functions of information processing, blocking, regulation and software and logic control. Many have one or more physical ports for transmitting information to other automation systems.

Some types of PLCs are highly reliable, durable and fast. They provide various options for complete current diagnostics of faults with their localization to a separate board, backup of individual components and the device as a whole [2, 4].

1. Analysis of recent research and publications

Massive practical application of PLCs revealed not only their unconditional advantages over other controls, but also significant shortcomings, the main of which is the consistent principle of information processing, which leads to a certain contradiction between the fantastic speed of modern hardware (clock speed is already tens of GHz) and short length of machine words.

It turns out that the speed of maintenance of controlled inputs of the controller significantly depends on their number. In addition, microprocessor-based PLCs often do not provide the required level of reliability and reliability of data processing due to the large number of sequentially executed commands in the management of critical applications (in nuclear power, rail and metro, aircraft) and therefore for direct control. units and installations in the specified branches are used extremely limited [5, 6, 10].

The aim of the article is increasing the speed and reliability of the implementation of the functions of logical control of automation objects by developing models and information technology for parallel logical control.

2. Basic research materials

In [1, 3] the structure of an asynchronous programmable automaton is described (Fig. 1), which is the basic structure of matrix parallel logic controllers for different functional purposes.

The principles of construction of an asynchronous programmable automaton controlled by the flow of input states and its structure were used in the development of methods of structural construction and actual structural organization of matrix PLCs with parallel architecture (PPLK) as functionally complete control devices [7–9].

A significant number of variants of structural organization of specialized and universal models of PPLK for different purposes have been developed.

The principle of operation of the considered control automaton is as follows. Let at the i -th moment of time from the matrix $[MC]$ the row vector of control commands $\{ci_1, ci_2, \dots, ci_m\}$ is read. This row vector is checked for a match with those programmed in the matrix $[ME]$ prohibited combinations of control commands, and in the presence of such a match, the function ε takes the value of logical "1", which leads to the prohibition of issuing the vector of control commands to the output of the automaton.

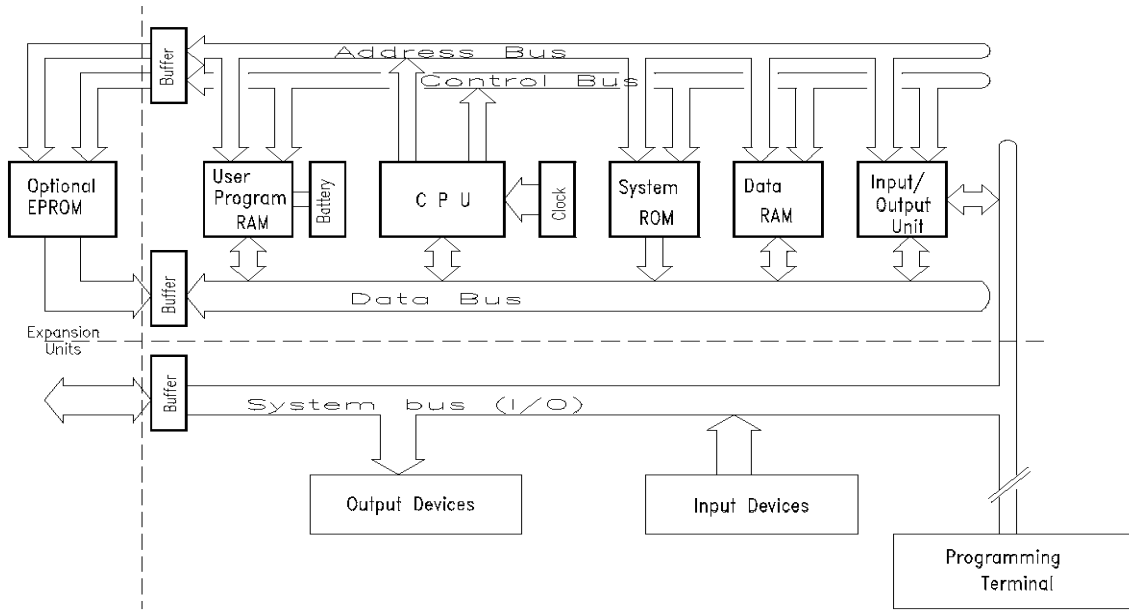

Fig. 1. The structure of the asynchronous programmable machine

If the function $\varepsilon=0$, the vector $\{ci_1, ci_2, \dots, ci_m\}$ generates commands for controlling the actuators $\{ci'_1, ci'_2, \dots, ci'_m\}$, under the influence of which the state of the controlled object changes, resulting in the inputs of the automaton the vector $\{ai_1, ai_2, \dots, ai_k\}$ is formed, which in parallel for all components k is compared for logical equivalence with the vector programmed on the given line of the program by the row of the matrix $|MA| = \{Ai_1, Ai_2, \dots, Ai_k\}$, i.e. In this case, the logical operation "AND" or the logical operation "OR" is performed according to the value of the attribute F_p .

Similarly, a comparison is made for equivalence of the vector of actual states of the external environment (vector of conditions) $\{bi_1, bi_2, \dots, bi_u\}$ with the programmed values of the matrix vectors $|MB| = \{Bx_1, Bx_2, \dots, Bx_u\}$, where the index x ranges from 1 to n , (i.e. the entire matrix $|MB|$ is analyzed simultaneously), thus, the logical function β_p .

The block that performs the functions of logical control is described by the following system of equations, which is a generalization of equations

$$\begin{cases} A = \beta_p \vee ST_p \vee Int1_p \\ +I = \alpha_p \wedge \overline{\beta_p} \wedge \overline{ST_p} \wedge \overline{Int1_p} \end{cases} \quad (1)$$

Depending on the truth of the logical functions α_p and β_p , as well as the values of the signs ST_p and $Int1_p$, the step function of the algorithm $I = g(p)$ takes the value "+1", which means the transition to the next step of processing the current subroutine, or the value "A", which means a conditional jump to the first line of the subroutine whose address is written in the matrix $|MB|$.

The described automaton can be considered as a kind of universal control device, since it can be used to implement sequential, situational control algorithms (in which the entire cyclogram consists of elementary (in one line) subcycles, the sequence of processing of which is determined only by the situation that has developed in the external environment in i -th moment of time) and situationally sequential as well (in which the start of processing the f -th subcycle is determined by the situation prevailing in the environment and at the control object at the i -th moment of time, and the elements of the subcycle are processed sequentially). Depending on the implemented type of algorithm, all or part of the automaton structure elements are used. So, for example, when implementing unbranched sequential algorithms, a truncated version of the structure (without $|MB|$) can be used.

To improve the quality of diagnosis, it is proposed to equip the PLC with a classical architecture with a FPGA-based operation control device (PCF). The electrical block diagram of the software control system using SCS is shown in Fig. 3. This system consists of two logic controllers (PLC) - working and diagnosing. The first is needed to process the input signals, solve logical equations specified by the program, and submit signals to the controlled object. The second must respond to combinations of input (or output) signals that are prohibited or may result in process equipment accidents or accidents. FPGA - parallel action controller can be used as a diagnostic device.

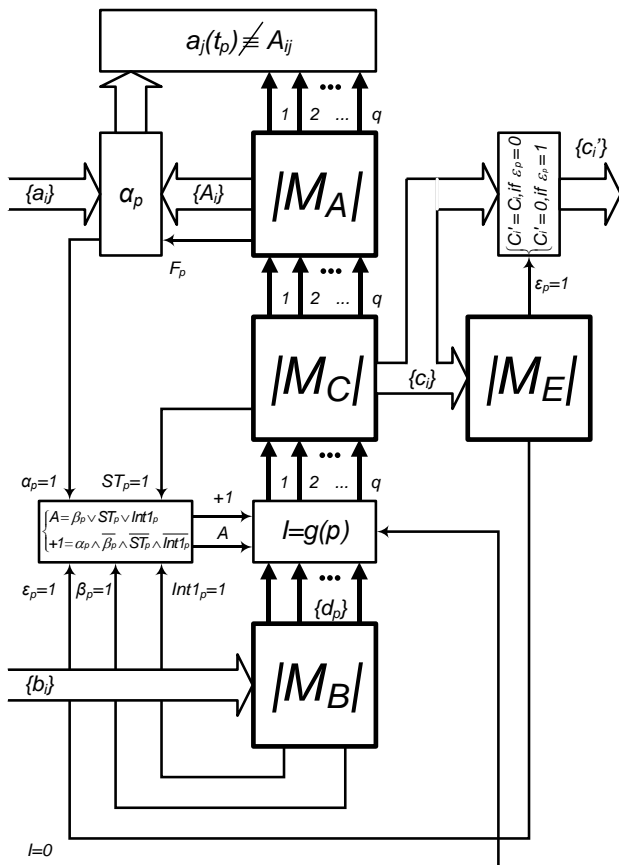

Fig. 2. The structure of the logical control automaton parallel action

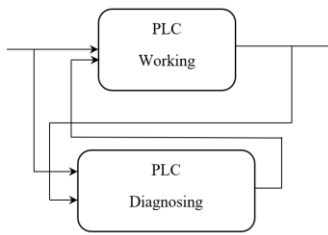

Fig. 3. Electrical block diagram of the software control system using SCS

In Fig. 4 shows a block diagram of the algorithm of the SCS PLC. First, the "Automatic" mode is started, the presence of the "Automatic" mode is checked. If it is enabled – the program proceeds to compare the combinations of input and output signals of the main PLC with the wrong and dangerous combinations. When either incoming or outgoing signals match with false ones, alarm routines are triggered. After the subroutines are run, the program returns to the beginning and the algorithm is run again.

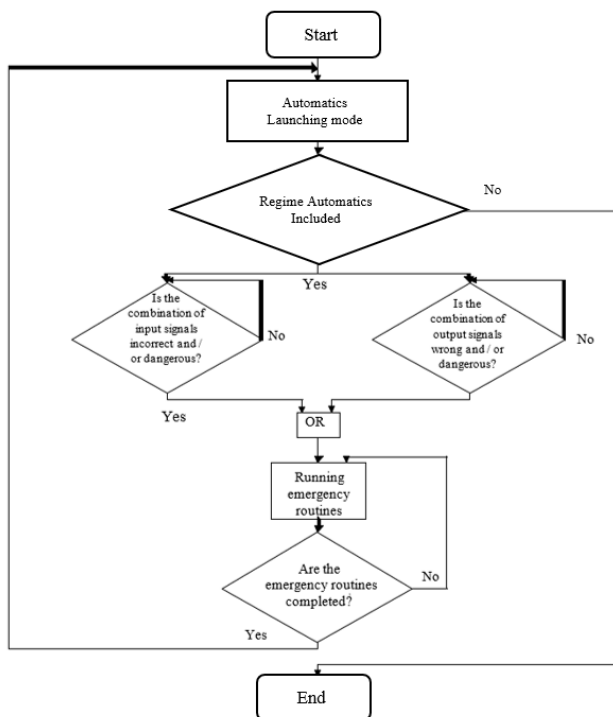

Fig. 4. Block diagram of the algorithm of the SCS PLC

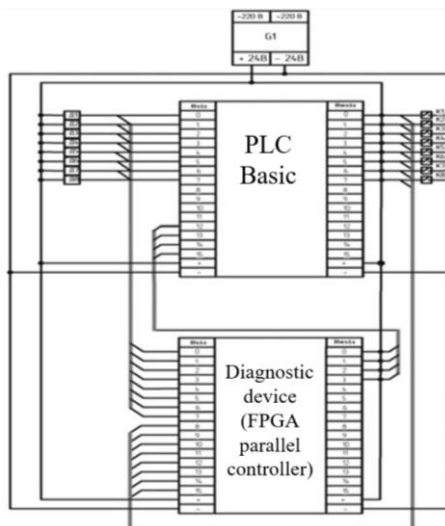

Fig. 5. Schematic electrical diagram of the software control system using SCS

The scheme of the electrical principle of the software control system with the use of SCS PLC is shown in Fig. 5. The software control system consists of a PLC of the main TWIDO TWD LCAA 16 DRF from Schneider Electric, a PLC of the diagnostician (FPGA-parallel controller) and a 220/24 V power supply. and inputs 12–15 – signals from outputs 0–3 of the diagnostic PLC. Signals from sensors D1-D8 are fed to inputs 0–7 of the diagnosing PLC, and signals from outputs 0–7 of the main PLC are fed to inputs 8–15, which are compared with emergency combinations for matches.

3. Conclusions

Knowledge of the general theoretical principles for constructing highly efficient computing and control devices based on homogeneous microelectronic structures, the emergence of modern FPGAs and their adaptability to programming using languages oriented to parallel logical data processing creates objective prerequisites for developing a fundamentally new approach to the structural organization of logical control automata. expressed parallel action and creation on this basis of information technology for parallel logical control of automation objects.

A combined solution using FPGA-based operation control device is proposed, which allows to expand the area of practical application of PLCs with parallel architecture. The proposed methodology for constructing a logical control automaton of parallel action, the developed models, algorithm and structures represent a theoretical platform for the practical implementation of information technology for parallel logical control of railway automation objects.

The prospect of further research is the development of a language, automated technology and tools for programming algorithms for parallel logical control of automation objects.

References

- [1] Badretdinov I. et al.: Mathematical modeling and study of the grain cleaning machine sieve frame operation. INMATEH-Agric. Eng. 60, 2020, 19–28.
- [2] Bazaluk O. et al.: Energy Saving in Electromechanical Grain Cleaning Systems. Appl. Sci. 12, 2022, 1418.
- [3] Furman I. O., Piskarev O. M., Staroverov R. M.: Analysis of promising technologies for automation of grain cleaning and sorting processes. Bulletin of the Kharkiv National Technical University of Agriculture. Problems of energy supply and energy saving in the agro-industrial complex of Ukraine 37(2), 2005, 143–146.
- [4] Furman I. O., Radchenko S. S.: Principles of construction and industrial implementation of ASKTP of elevator complexes of grain storage. Visnyk of Kharkiv National Technical University of Agriculture, named Petro Vasylenko. Problems of energy supply and energy saving in the agro-industrial complex of Ukraine 165, 2015, 79–80.
- [5] Giyevskiy A. M. et al.: Substantiation of basic scheme of grain cleaning machine for preparation of agricultural crops seeds. IOP Conf. Ser. Mater. Sci. Eng. 327, 2018, 042035.
- [6] Halko S., Suprun O., Miroshnyk O.: Influence of temperature on energy performance indicators of hybrid solar panels using cylindrical cogeneration photovoltaic modules. IEEE 2nd KhPI Week on Advanced Technology, KhPIWeek2021, 2021, 132–136.
- [7] Havrylenko Y. et al.: Representation of a monotone curve by a contour with regular change in curvature. Entropy 23, 2021, 923.
- [8] Mudarisov S. G., Badretdinov I. D.: Numerical implementation of a mathematical model of the technological process of the diametric fan in a rotating coordinate system. News Int. Acad. Agr. Educ. 17, 2013, 79–83.
- [9] Mudarisov S. G., Badretdinov I. D.: Substantiation of the parameters of the diametric fan based on a mathematical model of the process of its operation. International Scientific-Practical Conference in the Framework of the XXIII International Specialized Exhibition AgroComplex-2013, 2013, 363–367.
- [10] Piskarev O. M., Staroverov R. M.: Application of microprocessor control system in non-traditional scheme of grain cleaning and sorting. Bulletin of the Kharkiv National Technical University of Agriculture. Problems of energy supply and energy saving in the agro-industrial complex of Ukraine 27(2), 2004, 163–166.
- [11] Tabor S. et al.: Mathematical simulation of separating work tool technological process. E3S Web Conf. 132, 2015, 01025.

D.Sc. Sergiy Tymchuk

e-mail: stym@i.ua

Sergiy Tymchuk received the Doctor of Technical Sciences degree from the National Technical University "Kharkiv Politechnic Institute", Kharkiv, Ukraine, all in electrical power engineering. He is the author of three books, more than 200 articles, and more than 10 inventions. His research interests include the Smart Grid, renewable energy, quality of electrical energy, losses of electrical energy, overhead power lines monitoring, power system automation.

<http://orcid.org/0000-0002-8600-4234>

**Ph.D. Oleksiy Piskarev**

e-mail: post@3g.ua

Piskarev, Oleksiy received the M.Sc. degree from the National Technical University "Kharkiv Politechnic Institute", Kharkiv, Ukraine, and the Candidate of Technical Sciences degree from the National Technical University "Kharkiv Politechnic Institute", Kharkiv, Ukraine, all in electrical power engineering. He is the author of three books, more than 50 articles, and more than 5 inventions. His research interests include the Smart Grid, renewable energy, quality of electrical energy, losses of electrical energy, overhead power lines monitoring, power system automation.

<http://orcid.org/0000-0002-6980-984X>

**D.Sc. Oleksandr Miroshnyk**

e-mail: omiroshnyk@ukr.net

Oleksandr Miroshnyk received the M.Sc. degree from the Kharkiv State Technical University of Agriculture, Kharkiv, Ukraine, in 2004, and the Doctor of Technical Sciences degree from the National Technical University "Kharkiv Politechnic Institute", Kharkiv, Ukraine, in 2016, all in electrical power engineering. He is the author of three books, more than 200 articles, and more than 30 inventions. His research interests include the Smart Grid, renewable energy, quality of electrical energy, losses of electrical energy, overhead power lines monitoring, power system automation.



<http://orcid.org/0000-0002-6144-7573>

Ph.D. Serhii Halko

e-mail: galkosv@gmail.com

Serhii Halko graduated from Melitopol Institute of Mechanical Engineers of Agriculture, Ukraine, in 1994, and was qualified as an Electrical Engineer. He received his Ph.D. in Electric Engineering (power stations, systems and networks) from the Donetsk National Technical University, Ukraine, in 2003. Presently, he is an Assistant Professor of Dmytro Motornyi Tavria State Agrotechnological University and Educational Scientific Institute of General University Training, Melitopol, Ukraine. He is the author of more than 100 scientific publications, 10 inventions, and two monographs. His research interests are related to research in the field of renewable and alternative energy.

<http://orcid.org/0000-0001-7991-0311>

Ph.D. Taras Shchur

e-mail: shchurtg@gmail.com

Taras Shchur received the M.Sc. degree from the Kharkiv State Technical University of Agriculture, Kharkiv, Ukraine, in 2004, candidate of technical sciences Kharkiv Petro Vasylenko National Technical University of Agriculture in 2010.

He is the author of one book, more than 60 articles. His research losses of electrical energy, overhead power lines monitoring, power system automation.

<http://orcid.org/0000-0003-0205-032X>

