

DYNAMIC AND MATHEMATICAL MODELS OF THE HYDROIMPULSIVE VIBRO-CUTTING DEVICE WITH A PRESSURE PULSE GENERATOR BUILT INTO THE RING SPRING

Roman Obertyukh¹, Andrii Slabkyi¹, Leonid Polishchuk¹, Oleksandr Povstianoi²,
Saule Kumargazhanova³, Maxatbek Satymbekov⁴

¹Vinnitsia National Technical University, Vinnitsia, Ukraine, ²Lutsk National Technical University, Lutsk, Ukraine, ³D. Serikbayev East Kazakhstan Technical University, Ust-Kamenogorsk, Kazakhstan, ⁴Al-Farabi Kazakh National University, Almaty, Kazakhstan

Abstract. Structural calculation scheme of the hydropulse device for vibration cutting with built-in ring with pressure pulse generator (PPG) is considered. On the basis of the structural scheme and cyclogram of the working cycle of the device, its dynamic and mathematical models were developed, in which the hydraulic link is represented by a visco-elastic model of the working fluid (energy carrier) composed of the inertial elastic and dissipative elements (Kelvin-Foiga's body).

Keywords: mathematical model, dynamic model, hydropulse device, ring spring, frequency, amplitude

MODELE DYNAMICZNE I MATEMATYCZNE HYDRAULICZNEGO URZĄDZENIA IMPULSOWEGO DO CIĘCIA WIBRACYJNEGO Z GENERATOREM IMPULSÓW WBUDOWANYM W SPRĘŻYNĘ PIERŚCIENIOWĄ

Streszczenie. Rozważa się schemat konstrukcyjny i projektowy hydraulicznego urządzenia impulsowego do cięcia wibracyjnego z wbudowanym generatorem impulsów ciśnieniowych ze sprężyną pierścieniową (PPG). Na podstawie schematu strukturalnego i cyklu pracy urządzenia opracowano jego modele dynamiczne i matematyczne, w których ogniwo hydrauliczne reprezentowane jest przez lepkosprężysty model cieczy roboczej (nośnika energii), złożony z bezwładnych elementów sprężystych i dyssypacyjnych (ciała Kelvina-Foiga).

Słowa kluczowe: model matematyczny, model dynamiczny, hydrauliczne urządzenie impulsowe, sprężyna pierścieniowa, częstotliwość, amplituda

Introduction

Vibration cutting and vibration turning in particular, in comparison with conventional turning, have a number of known technological advantages, especially when processing viscous materials such as stainless steels and titanium alloys [6]. The massive introduction of vibration cutting processes is constrained by the practical absence of compact, with a wide range of vibration loading parameters, devices. The authors of the work proposed a number of designs for devices for vibration cutting on the basis of a hydropulse drive using elastic elements of high rigidity such as slit, plate and ring springs [16]. The novelty of the developed designs is confirmed by dozens of patents for utility models of Ukraine.

The purpose of conducting theoretical studies of dynamic processes, which reflect their course in the studied devices, as well as their experimental verification, which establishes the adequacy of the mathematical model to real physical processes, is the development of a scientifically based methodology for the design calculation of the created structure, which allows optimization of its design parameters [5, 6, 7].

1. Analysis of research methods

Research of oscillating systems by theoretical methods [5, 7, 9] is in most cases carried out by researching mathematical models, in particular hydraulic impulse machines – by researching the mathematical model of the executive links in the form of differential equations of motion and equations of the consumption of the energy carrier flowing through the pressure pulse generator (PPG) during the working cycle. In the case of applying the macromodeling method to simplify the original mathematical model, only those variables that influence, in the researcher's opinion, the most, are taken into account in the initial space of variables. Other unaccounted for effects can be taken into account in a parametric form by changing the coefficients near the considered variables for the case of multiplicative effects or by introducing free terms in the equations for the case of additive effects. This approach is quite often used to simplify the mathematical models of the hydraulic impulse drive, in particular, the PPG operation is considered to be instantaneous ("relay"). With this approach, it is not possible to adequately

describe the dynamics of this issue, and it creates significant discrepancies between the results of theoretical and experimental research.

In our opinion, studies of simplified models that describe the cycle of the hydraulic impulse vibration drive as a single-act process [2, 10] significantly reduce the correctness of the results of theoretical studies of the processes taking place in the vibration drive and the machine as a whole.

Modern software tools for mathematical modeling of physical processes make it possible to study the dynamics of processes occurring in oscillating systems without simplifying mathematical models. Taking into account all stages of the work cycle of the drive elements ensures the possibility of creating correct methods for the design calculation of the design of the machine or device.

The mathematical models of the hydropulse drive, built on the basis of a detailed step-by-step analysis of the driving cycle of the drive [9, 12], are more correct, and the engineering calculation methods developed on the basis of these models allow to determine the design, power and power parameters of the PPG and the drive, which more precisely with the experimentally established ones under the same conditions initially set during simulation [11, 15].

An important aspect of mathematical models and methods of calculating the hydropulse drives is the choice of model of energy. Known mathematical models of the drive are based in the simplest forms on the "rigid" [10, 13] model of the energy carrier, which does not take into account the elastic and viscous characteristics of the energy carrier, and in more precise forms an „elastic” energy carrier model is used that takes into account the elastic properties of the fluid [3, 8, 14].

2. Theoretical studies

The structural scheme of the hydropulse device for vibration cutting with a built-in ring spring (further RS1) by a pulse pressure generator in a constructive form is shown in Fig. 1.

The device consists of two hydraulically connected units – the PPG and the hydraulic cylinder of the drive in a vibratory movement, for example a turning cutter for radial vibration. The PPG contains a locking element in the form of a valve-spool of 1 mass m_{k3} , the right-hand side (according to the drawing) which is a supporting ring of a ring-spring PPG (RS1) with

rigidity k_1 and mass m_{k1} , consisting of a set of outer 2 and inner 3 rings that interact with each other by the mediation of internal and external conical surfaces. The pre-deformation y_{01} of the PPG ring spring is controlled by means of a screw 4 that moves the pressure plunger 5, the left end (which is illustrated) is designed as the second bearing ring RS1. The plunger 5 is sealed with a rubber ring of 6 round sections. The body of the PPG and the device in general is not conventionally shown in Fig. 1

With the block of the hydraulic cylinder actuator (located in the unit body, like the PPG), the PPG is combined through a common pressure cavity A (hole diameter d_1). The hydraulic cylinder consists of a plunger of 7 with a mass m_{pl} compacted by a rubber ring 8. On the right (in the drawing) of the end of the plunger 7, a protrusion is formed which is the support and guide surface of the bearing ring 9 of the ring spring, the hydraulic cylinder (RS2), the stiffness k_2 and the mass m_{k2} .

RS2 consists of external 10 and internal 11 rings and two identical in shape and sizes of support rings 9 and 12. The rings RS2 are in contact with each other through the inner and outer conical surfaces. The pre-deformation y_{02} of the RS2 is controlled by means of a collar nut 13 that is screwed onto the threaded projection 14 of the device casing conventionally shown by an icon „x”. The nut 13 clicks on the step cap 15 in the inner dull groove which places and regulates the left (as shown in the drawing) bearing ring 12 RS2. The nut 13 is locked with a spline nut 16.

In the rectangular aperture of the step cap 13, a cutter 17 is provided, equipped with a cylindrical rod 18 with a buccal ledge. The right part of the rod 18 (behind the buckling protrusion) enters the landing gear in the central hole of the plunger 7, and a spring 19 is installed on the left part of the rod 18 (in front of the hill), with one end resisting the bust of the rod, and the other to the cover 13. The spring 19 is installed during the assembly of the hydraulic cylinder with the estimated pre-deformation and carries the axial pre-fixing of the cutter 17.

In order to provide a stable mode of landing the valve-spool 1 at the end of its reverse, a throttle 20 is provided. The function of the throttle 20 can be provided by the gap in the conjugation of the valve-spool 1 by the diameter d_2 of the mortar in the body (or the sleeve in the real construction) of the device or by the experimentally selected folding length $l_L \geq h_d$ (here h_d – a positive overlap of the spool valve part-spool 1) connects intermediate B and drain C device cavity. The placement cavity RS1 is connected to the drainage cavity with radial openings „a” in the direct part of the valve-spool 1.

Power supply of the working fluid (energy carrier) is carried out from a compact hydro pump station, which connects to the device with two flexible hoses of high pressure. The energy supply sleeve joins the pressure cavity A, and the sleeve

of the drainage C connects the latter with the hydraulic tank of the station.

Given the radial stretching of the outer rings 2 and 10 RS1 and RS2 during their working deformation, the cylindrical surfaces of the outer rings 2 and 10, which RS1 and RS2 are guided in the holes of the device body, are tied to the surfaces of the holes of the hull under running landings not exceeding 9-10 qualifications. Since, in absolute value, the radial deformations of the rings are small, the gaps that provide the named qualities are guaranteed to exclude the possible stitching of the rings [1, 4, 17].

The „opening” pressure of the PPG is determined by the known dependence [3, 14, 16]

$$p_1 \geq k_1 \cdot y_{01} / A_1 = 4k_1 \cdot y_{01} / (\pi d_1^2) = 0,785k_1 \cdot y_{01} / d_1^2, \quad (1)$$

where $A_1 = \pi d_1^2 / 4 = 0,785d_1^2$ – the area of the cross-section along the facet of the valve-spool 1 for its small diameter d_1 (the first degree of sealing of the sealing element of the PPG – valve-spool 1), provided that the sealing is carried out on a facet of small width, which can be calculated according to the formulas given in the work [17].

The movement of the plunger 7 of the hydraulic cylinder of the drive of the cutter 17 in the vibrational movement will begin after the increase in the pressure of the energy carrier in the pressure cavity A to the level (without taking into account frictional forces between the plunger 7 and its guiding surface)

$$p_c \geq k_2 y_{02} / A_3 = 4k_2 y_{02} / (\pi d_3^2) = 0,785k_2 y_{02} / d_3^2, \quad (2)$$

where p_c – stationary pressure of the energy carrier, at which the plunger 7 movement begins 7; $A_3 = \pi d_3^2 / 4 = 0,785d_3^2$ – square cross-section of the plunger 7.

The maximum possible displacement of the plunger 7 and the cutter 17, because due to the force of the spring 19, it is located with a plunger 7 in a rigid contact, can be estimated from the equation of dynamic equilibrium:

The maximum possible displacement h_{Fmax} of the plunger 7 and the cutter 17, because due to the force of the spring 19, it is located with a plunger 7 in a rigid contact, can be estimated from the equation of dynamic equilibrium:

$$p_1 \cdot A_3 = k_2 (y_{02} + h_{Fmax}) \quad (3)$$

where

$$h_{Fmax} = p_1 A_3 / k_2 - y_{02max} \approx 0,785 p_1 d_3^2 k_2^{-1}. \quad (4)$$

The displacement h_F of the plunger 7 is essentially the amplitude of the vibration oscillations of the cutter 17 and, as can be seen from dependence (4), can be regulated by changing the energy pressure p_1 and previous deformation y_{02} of the RS2.

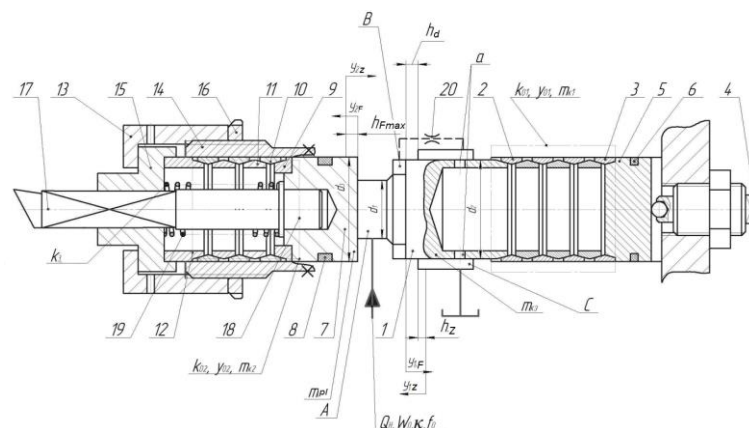

Fig. 1. Structural diagram of the hydropulse device for vibratory turning device with a pressure pulse generator built into the ring spring PPG

3. Results

Taking into account the given structure of assumptions and the oriented cyclogram of the working cycle [11, 12, 15], the dynamical models of the direct (Fig. 2a) and reverse (Fig. 2b) moves of the valve-spool 1 and plunger 7 (cutter 17) (see Fig. 1) they consist of two lumped masses m_1 and m_2 interact with HL , in the form of connected parallel elastic k_{or} and dissipative c_o elements, due to the transfer ratios $U_{01(02)}$ and U_{03} . HL during the operating cycle of the device deforms with variable speed \dot{x}_{or} in directions x_{or} .

Moving masses m_1 and m_2 during their direct (y_{1F} and y_{2F}) and reverse (y_{1Z} and y_{2Z}) moves counteract the positional forces of elastic resistance, which are characterized by stiffness k_1 , k_2 and k_3 viscous resistance, the level of which is determined by the coefficients c_1 and c_2 and velocities \dot{y}_{1F} , \dot{y}_{2H} , \dot{y}_{1Z} and \dot{y}_{23} by the force of dry friction R and the force of cutting F_y , which supposed to act only during direct mass m_2 movement.

An important point in the use of RS1 and RS2 as power elastic elements of the PPG and the hydraulic cylinder of the drive cutter 17 in the vibratory motion is to determine their rigidity and deformation (deposition) under the action of the maximum axial forces acting on RS1 F_{a1max} and RS2 F_{a2max}

$$F_{a2max} = p_{1max} \cdot A_3, \tag{5}$$

$$F_{a1max} = p_{1max} \cdot A_2; \tag{6}$$

where p_{1max} – the maximum possible pressure „opening” the PPG.

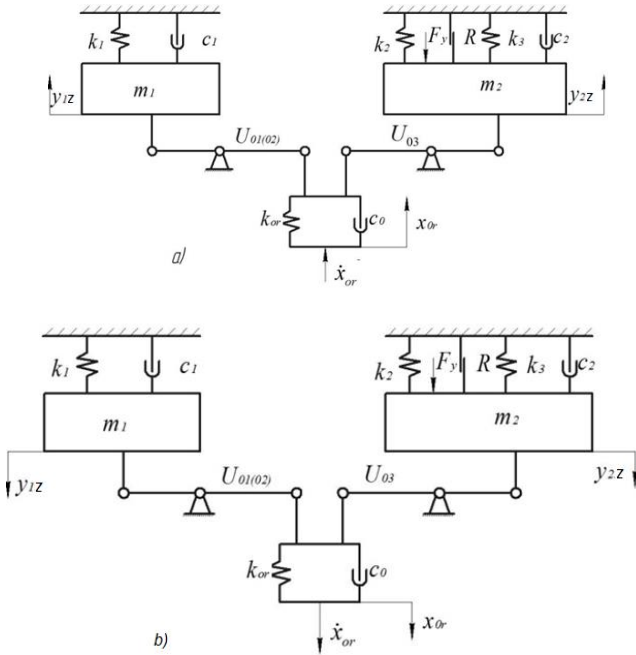

Fig. 2. Dynamic models of direct a) and reverse b) mass movements m_1 and m_2

The determination of the rigid and structural parameters of RS1 and RS2 can be made on the basis of known works [4, 17] in the calculation and design of ring springs.

To construct a mathematical model of the device for vibration cutting, the initial dynamic models of direct and reverse moves of the model of direct and reverse mass movements m_1 and m_2

expediently to simplify the principle of dismemberment [15] by bringing the HL to mass m_1 and m_2 .

As a result of this reduction, we obtain four simple dynamic models of direct (Fig. 3a, b) and reverse (Fig. 3c, d) of mass m_1 and m_2 .

On the basis of the principle of D'Alembert, we compile with the help of the given dynamic models the differential equations of the movement of the valve-spool 1 (mass m_1) and the executive link of the device of the plunger 7 (cutter 17) (mass m_2 , see Fig. 1) during the moves:

direct ($x_{01} \geq x_{0r} \geq x_{02}$) :-

$$\begin{cases} m_1 \ddot{y}_{1H} = U_{01(02)} \cdot k_{or} (x_{A1(2)} - y_{1H}) - k_1 (y_{1H} + y_{01}) - c_1 \dot{y}_{1H} - U_{01(02)}^{0.25} \cdot c_o (\dot{x}_{A1(2)} - \dot{y}_{1H}); \\ m_2 \ddot{y}_{2H} = U_{03} \cdot k_{or} (x_{A3} - y_{2H}) - k_2 (y_{2H} + y_{02}) - k_3 (y_{2H} + y_{03}) - U_{03}^{0.25} \times \\ \times c_o (\dot{x}_{A3} - \dot{y}_{2H}) - R - F_y - c_2 \dot{y}_{2H}; \end{cases} \tag{7}$$

reverse ($x_{02} \geq x_{0r} \geq 0$):

$$\begin{cases} m_1 \ddot{y}_{13} = k_1 (y_{01} + h_k + y_{13}) - U_{01(02)} \cdot k_{or} [x_{A1(2)} - (h_k - y_{13})] - U_{01(02)}^{0.25} \cdot c_o (\dot{x}_{A1(2)} - \dot{y}_{13}) - c_1 \dot{y}_{13}; \\ m_2 \ddot{y}_{23} = k_2 (y_{02} + h_{Hmax} - y_{23}) + k_3 (y_{03} + h_{Hmax} - y_{23}) - U_{03} \cdot k_{or} [x_{A3} - (h_{Hmax} - y_{23})] - \\ - U_{03}^{0.25} \cdot c_o [x_{A3} - (h_{Hmax} - y_{23})] - R - c_2 \dot{y}_{23}, \end{cases} \tag{8}$$

where

$$x_{01} = p_1 A_0 \cdot k_{or}^{-1}; \tag{9}$$

$$x_{02} = p_2 A_0 \cdot k_{or}^{-1} = x_{01} \cdot U_{21}^{0.5} + k_1 h_k U_{02}^{-0.5} \tag{10}$$

the boundary deformations of HL ; $U_{21} = A_1^2 \cdot A_2^{-2}$ for $0 < y_{1F} \leq h_k$ and $0 \leq y_{1Z} \leq h_k$; $x_{A1(2)} = x_{or} \cdot U_{01(02)}$; $\dot{x}_{A1(2)} = \dot{x}_{or} \cdot U_{01(02)}$; ($x_{A1(2)}$ and $\dot{x}_{A1(2)}$ are determined by changes $U_{01(02)}$ on the interval $0 < y_{1F} \leq h_k$); $x_{A1(2)} = x_{or} \cdot U_{01(02)}$; $\dot{x}_{A1(2)} = \dot{x}_{or} \cdot U_{01(02)}$; ($x_{A1(2)}$ and $\dot{x}_{A1(2)}$ are determined by changes $U_{01(02)}$ on the interval $0 \leq y_{1F} \leq h_k$); $x_{A2(1)} = x_{or} \cdot U_{01(02)}$; $\dot{x}_{A2(1)} = \dot{x}_{or} \cdot U_{01(02)}$; ($x_{A2(1)}$ and $\dot{x}_{A2(1)}$ are determined by changes $U_{01(02)}$ on the interval $0 \leq y_{1F} \leq h_k$); $x_{A3} = x_{or} \cdot U_{03}$; $\dot{x}_{A3} = \dot{x}_{or} \cdot U_{03}$; y_{1F} , y_{2F} , y_{1Z} , y_{2Z} , \dot{y}_{1F} , \dot{y}_{2F} , \dot{y}_{1Z} , \dot{y}_{2Z} – respectively, the current coordinates and velocities of the masses m_1 and m_2 during the direct and the return of their moves; y_{03} – predeformation of the spring 19 (see Fig. 1).

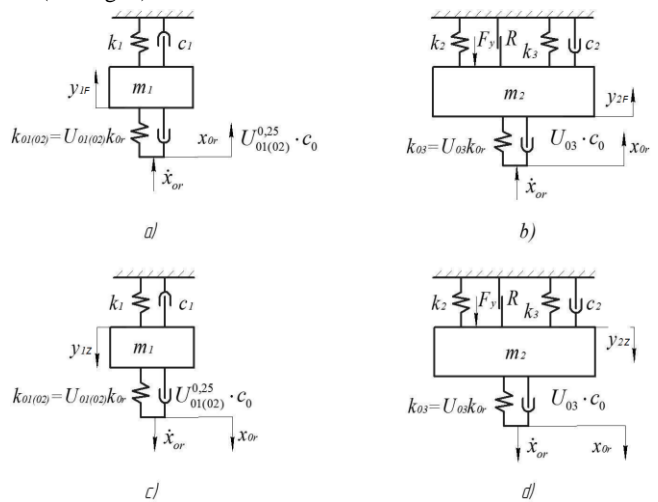

Fig. 3. Simplified dynamic models of direct (a, b) and inverse (c, d) mass movements m_1 and m_2

Differential equations of systems (7) and (8), in order to exclude free members, replace variables y_{1F} , y_{2F} , y_{1Z} and y_{2Z} variables:

$$\begin{aligned} z_{1F} &= y_{1F} + \omega_{\Sigma 1}^{-2} \omega_{01}^2 y_{01}; \\ z_2 &= y_{2F} + \omega_{\Sigma 1}^{-2} [\omega_{02}^2 y_{02} + \omega_{03}^2 y_{03} + (R + F_y) m_{\Sigma}^{-1}]; \\ z_{1Z} &= y_{1Z} - \omega_{\Sigma 1}^{-2} [\omega_{01}^2 (y_{01} + h_k) + \omega_{p1}^2 U_{02} h_k]; \\ z_{2Z} &= y_{2Z} - \omega_{\Sigma 2}^{-2} [\omega_{02}^2 (y_{02} + h_{F \max}) + \omega_{p2}^2 U_{03} h_{F \max} + (R + F_y) m_2^{-1}], \end{aligned} \quad (11)$$

where:

$$\omega_{\Sigma 1} = \sqrt{\omega_{p1}^2 U_{01(02)} + \omega_{01}^2};$$

$$\omega_{p1} = \sqrt{k_{0r} m_1^{-1}};$$

$$\omega_{01} = \sqrt{k_1 \cdot m_1^{-1}};$$

$$\omega_{\Sigma 2} = \alpha \omega_{\Sigma 1};$$

$$\omega_{p2} = \gamma^{-1} \omega_{p1};$$

$$\omega_{02} = \gamma^{-1} \cdot \delta \omega_{01};$$

$\omega_{03} = \gamma^{-1} \delta_1 \omega_{01}$ – own frequencies (circular) of the drive system, determined relative to the mass m_1 – respectively, the valve-spool system 1 – HL, HL solidified to the masses m_1 , valve-spool system 1, system of plunger 7 (cutter 17) – HL, reduced to mass m_2 , HL solidified to the masses m_2 ; plunger 7 (cutter 17), loaded with a spring 19; $\alpha = \{U_{HD} [1 + \omega_{01}^2 \omega_{\Sigma 1}^{-2} (\gamma^{-1} \delta U_{HD}^{-1} - 1)]\}^{0.5}$; $\gamma = m_1 / m_2$; $\delta = k_1 / k_2$; $\delta_1 = k_1 / k_3$; $U_{HD} = U_{03} / U_{01(02)}$ – the internal gear ratio between the hydraulic cylinder of the drive of the plunger 7 (cutter 17) and the PPG), which do not change the nature of the mass motion m_1 and m_2 , after corresponding algebraic transformations, can be brought into the form, respectively, for the direct and reverse mass movements m_1 and m_2 which, in form and content, describes the forced oscillations of these masses under the influence of variable oscillations of the amplitude of linear deformation x_{or} HL:

$$\begin{cases} \ddot{z}_{1F} + 2\beta_{1F} \dot{z}_{1F} + \omega_{\Sigma 1}^2 z_{1F} = \omega_{p1}^2 U_{01(02)}^{0.5} \cdot x_{or}; \\ \ddot{z}_{2F} + 2\beta_{2F} \dot{z}_{2F} + \alpha \omega_{\Sigma 1}^2 z_{2F} = \gamma^{-1} \omega_{p1}^2 U_{03}^{0.5} \cdot x_{or}; \\ \ddot{z}_{1Z} + 2\beta_{1Z} \dot{z}_{1Z} + \omega_{\Sigma 1}^2 z_{1Z} = -\omega_{p1}^2 U_{01(02)}^{0.5} \cdot x_{or}; \\ \ddot{z}_{2Z} + 2\beta_{2Z} \dot{z}_{2Z} + \alpha \omega_{\Sigma 1}^2 z_{2Z} = -\gamma^{-1} \omega_{p1}^2 U_{03}^{0.5} \cdot x_{or}; \end{cases} \quad (12)$$

where

$$\beta_{1F} = 0,5 m_1^{-1} [c_1 + U_{01(02)}^{0.25} \cdot c_0 (\dot{x}_{A1(2)} \dot{y}_{1H} - 1)];$$

$$\beta_{1Z} = 0,5 m_1^{-1} [c_1 + U_{01(02)}^{0.25} \cdot c_0 (\dot{x}_{A2(1)} \dot{y}_{1Z} - 1)];$$

$$\beta_{2F} = 0,5 m_2^{-1} [c_2 + U_{03}^{0.25} \cdot c_0 (\dot{x}_{AZ} \dot{y}_{2F} - 1)];$$

$$\beta_{2Z} = 0,5 m_2^{-1} [c_2 + U_{03}^{0.25} \cdot c_0 (\dot{x}_{AZ} \dot{y}_{2Z} - 1)] - \text{variable coefficients}$$

of damping during mass motion m_1 and m_2 . In order to complete the mathematical model of the hydropulse device for vibration cutting, the equation of energy-transport equation for the displacement of the valve-spool 1, plunger 7 (cutter 17) and the flow of energy into the tank through the open of the PPG must be added to the system of differential equations (36), and the uniqueness conditions that describe the displacement

of the PPGs and the hydraulic cylinder of the drive of the cutter 17 (see Fig. 1) at the characteristic intervals of time in the corresponding sections of the movement of the device links.

4. Conclusions

Comprehensive analysis and research of the proposed models of a hydropulse device for vibrating cutting with a pulse pressure generator built into the ring spring with subsequent experimental verification of the degree of adequacy of these models to the actual system of the device, will allow to create scientifically grounded method of design calculation of similar designs of devices with a hydropulse drive.

References

- [1] Abramov E. I. et al.: Elements of the hydraulic drive: reference book. Technics, Kiev 1977.
- [2] Berezyuk O. V.: Mathematical modeling of the hydraulic drive dynamics of the working bodies of the container reversal during the loading of solid household waste in the garbage truck. Bulletin of Khmelnytsky National University 5, 2013.
- [3] Bocharov Yu. A.: Fundamentals of the general theory of hydraulic forge-stamping machines. Machinery and technology of metal processing by pressure. Collection of scientific works MVTU 330, 1980, 12–40.
- [4] Chuprakov Yu. I.: Hydraulic actuator and means of hydraulics. Engineering 1979.
- [5] Cieplak G.: Estimation of the resonance amplitude in machines with inertia vibrator in the coast-down phase. Mechanics & Industry 19(102), 2018.
- [6] Danilchik S. S.: Vibration turning of structural steels. BNTU, Minsk 2018.
- [7] Gursky V. et al.: Dynamic Analysis of an Enhanced Multi-Frequency Inertial Exciter for Industrial Vibrating Machines. Machines 10(130), 2022 [http://doi.org/10.3390/machines10020130].
- [8] Iskovich-Lototskiy R. D. et al.: Pressure pulse generators for controlling the hydropulse drives of vibratory and vibration damping technological machines. UNIVERSUM, Vinnitsya 2008.
- [9] Iskovich-Lototskiy R. D. et al.: Vibration and vibro-shock machines. Technics, Kiev 1982.
- [10] Khmara L. A. et al.: Algorithm to calculate work tools of machines for performance in extreme working conditions. Mechatronic Systems I. Applications in Transport, Logistics, Diagnostics and Control. Taylor & Francis Group – CRC Press, New York 2021, 29–38.
- [11] Kozlov L. et al.: Optimization of design parameters of a counterbalance valve for a hydraulic drive invariant to reversal loads. Mechatronic Systems I. Applications in Transport, Logistics, Diagnostics and Control. Taylor & Francis Group – CRC Press, New York 2021, 137–148.
- [12] Kozlov L. G. et al.: Experimental research characteristics of counterbalance valve for hydraulic drive control system of mobile machine. Przegląd Elektrotechniczny 95(4), 2019, 104–109.
- [13] Obertyukh R. et al.: Mathematical Modeling of the Device for Radial Vibroturning. Advanced Manufacturing Processes II. Inter Partner, Springer, Cham. 2020 [http://doi.org/10.1007/978-3-030-68014-5_55].
- [14] Obertyukh R. et al.: Method of design calculation of a hydropulse device for strain hardening of materials. Przegląd Elektrotechniczny 4, 2019, 65–73.
- [15] Obertyukh R. R. et al.: Dynamic and mathematical models of the hydraulic-pulse device for deformation strengthening of materials. Proc. 10808, 2018.
- [16] Obertyukh R. R. et al.: Pat No 76517 Ukraine, IPC (2013, 01) B23B 1/00. Hydropulse vibrationshock device for radial and axial vibration turning with integrated pulse generator type pressure valve. Applicant and owner of the Vinnitsya National Technical University. 10.01.2013. Bull No. 1.
- [17] Polishchuk L. et al.: Mechatronic Systems II. Applications in Material Handling Processes and Robotics. Taylor & Francis Group – CRC Press, Boca Raton, London, New York, Leiden 2021.
- [18] Ponomarev S. D., Andreeva L. E.: Calculation of elastic elements of machines and instruments. Machine-building, Moscow 1980.
- [19] Roganov L. L., Karnaukh S. G.: Calculation of springs and elastic shock absorbers. DSEA, Kramatorsk 2000.
- [20] Song T.: Rapid Calculation and Optimization of Vibration and Noise of Permanent-Magnet Synchronous Motors for EVs Based on Equivalent Structural Network. Machines 10(4), 2022, 281 [http://doi.org/10.3390/machines10040281].
- [21] Wójcik W. et al.: Mechatronic Systems I. Applications in Transport, Logistics, Diagnostics and Control. Taylor & Francis Group – CRC Press, London, New York 2021 [http://doi.org/10.1201/9781003224136].

Ph.D. Roman Obertyukh
e-mail: obertyuh557@gmail.com

Ph.D., Associate Professor, Professor of department of industrial engineering Vinnytsia National Technical University, Research Interests: research and improvement of vibration technology.



<http://orcid.org/0000-0003-2939-6582>

Ph.D. Andrii Slabkyi
e-mail: slabkiyandrey@gmail.com

Ph.D., Associate Professor, Associate Professor of department of industrial engineering Vinnytsia National Technical University.

Research Interests: development and research of new technology samples, in particular for vibration cutting and surface deformation strengthening of machine parts.



<http://orcid.org/0000-0001-9284-2296>

D.Sc. Leonid Polishchuk
e-mail: leo.polishchuk@gmail.com

Doctor of Technical Sciences, professor, academician at the Ukraine Academy of Hoisting-and-Transport Sciences. Vinnytsia National Technical University. Head of the Department of Industrial Engineering at Vinnytsia National Technical University. The scientific focus is the dynamics of drive systems with devices and control systems with variable operating modes and diagnostics of metal structures of hoisting-and-transport and technological machines.



<http://orcid.org/0000-0002-5916-2413>

D.Sc. Oleksandr Povstianoi
e-mail: povstjanoj@ukr.net

Doctor of science, Professor of the Department of applied mechanics and mechatronics Lutsk National Technical University.

Research Interests: application and development of computer and information technologies in modern materials science



<http://orcid.org/0000-0002-1416-225X>

Ph.D. Saule Kumargazhanova
e-mail: SKumargazhanova@gmail.com

She is currently the dean of the Department of Information Technologies and Intelligent Systems of D. Serikbayev East Kazakhstan Technical University. She is a co-author over 50 papers in journals and conference proceedings.

Her professional interests are software engineering, data processing and analysis.



<http://orcid.org/0000-0002-6744-4023>

Ph.D. Maxatbek Satymbekov
e-mail: m.n.satymbekov@gmail.com

Assistant Professor of the Department of Computer Science of Al-Farabi Kazakh National University. Author of more than 25 scientific works published in leading journals of Kazakhstan Republic and the far abroad.

Research area: High performance computing, intelligent systems of control, software engineering, artificial intelligence, soft computing.



<http://orcid.org/0000-0002-4621-6646>